

## Fully Automatic Strapping Machine

The TRS-600 is an economical automatic strapping machine for wide straps (8-15.5 mm).

With proven quality and competitive price, it is the most cost effective solution for wide straps general purpose application.

- Easy operation, simple maintenance
- Quality steel construction, this strapping machine is designed for constant use in numerous applications
- Opening Size: 850mm wide x 600mm high
- Tension can be easily set with a dial
- Electrical Requirements: 220V 50Hz single phase

See this product on page 348 of the MHA catalogue

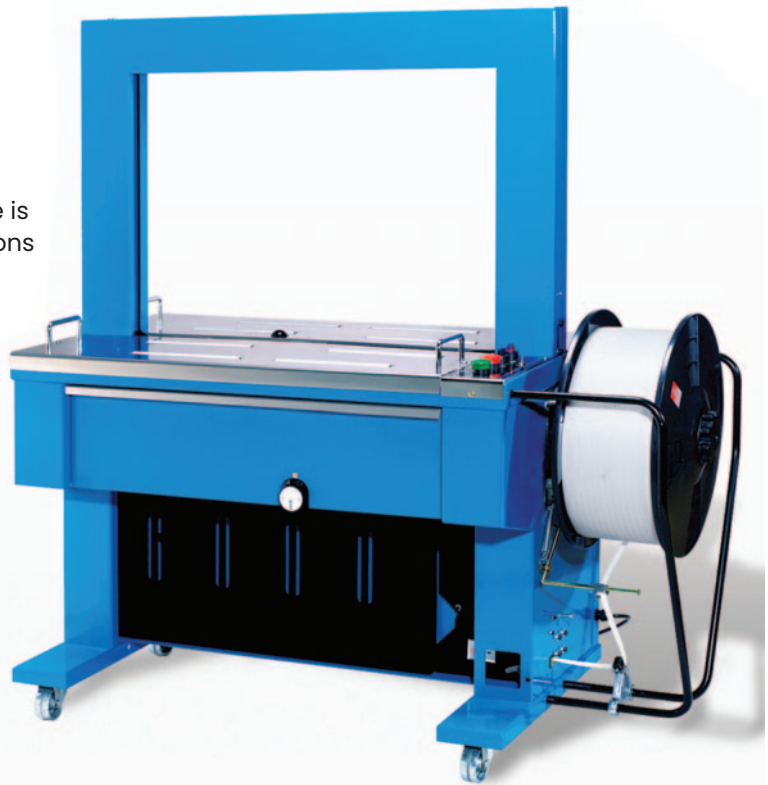
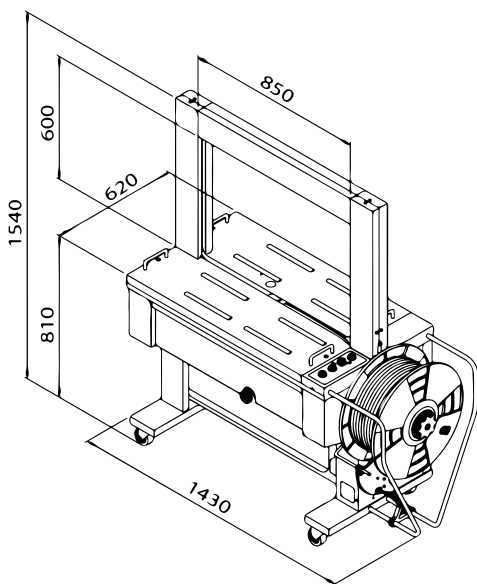

### OPTIONS

- Short feed sensor. The sensor will detect whether the strap is at sealing position. If not, the start switch cannot be activated.
- Stainless steel frame.
- Other arch sizes available on request. 850mm (W) x 1000mm (H), 1050mm (W) x 600mm (H) & 1050mm (W) x 800mm (H).

| Code   | Strap Width (mm) | Strap Thickness (mm) | Strap Tension (kg) | Strapping Speed | Overall Size LxWxH (mm) | Unit Weight (kg) |
|--------|------------------|----------------------|--------------------|-----------------|-------------------------|------------------|
| TRS600 | 8 - 15.5         | 0.55 - 0.75          | 10 - 70            | 27 straps/min   | 1430x620x1450           | 220              |

Visit [www.mhaproducts.com.au](http://www.mhaproducts.com.au) for more images and details

## ABOUT MHA PRODUCTS

At Manual Handling Australia (MHA), we have the largest range of manual handling and workplace materials handling equipment in Australia. This includes thousands of workplace and storage items suited to every workplace and lifting equipment and trolleys for almost every application. Our products aim to eliminate or reduce manual handling effort in the workplace, while boosting productivity and ensuring workplace safety.

MHA has over many years spent countless hours on product development and sourcing to ensure we can get products to make your workplace not only safer but more efficient.

MHA sources products from all over the world and sells them direct meaning there is no middle man or middle margin added giving you the best possible price and faster service. We also offer customised solutions with trolleys, lifters and many other materials handling equipment to ensure you have the perfect product to improve the safety and efficiency of your workplace.

MHA is dedicated to providing you with the highest quality products at the best possible price, with the best possible service. With a long and trusted reputation in the industry, MHA is a name you can rely on.