

# 1 Person Crane Platform Cage (with mesh roof)

The FC2962 1 person Crane Cage Work Platform has been designed strictly in accordance with Australian Standard AS 1418.17 and is suitable for a maximum of one person.

Work performed in this Cage shall be limited to special tasks of short duration in situations where necessary to elevate personnel where it is not practicable to erect scaffolds or use a specially designed device. Fork Arm slippers are provided for transport purposes only. The standard finish on the Cage is painted enamel in 'Safety Yellow'.

All Cages are supplied with a Load Test Certificate, Instructions for usage, Risk Control Measures and Workcover registration.

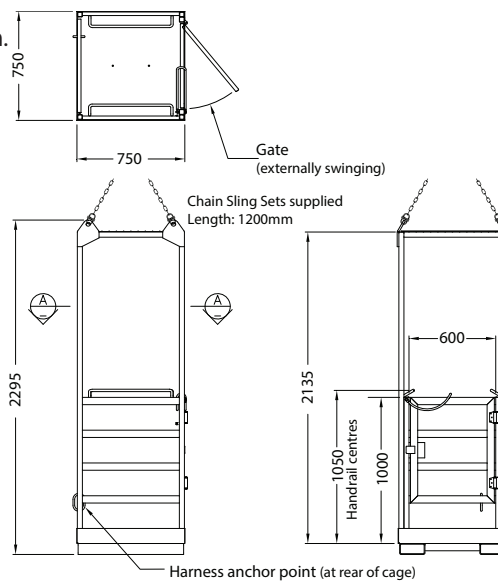

Code	Safe Working Load (kg)	Fork Pocket Size (mm)	Pocket Centres (mm)	Unit Weight (kg)
FC2962	250	165x65	555	150

Visit [www.mhaproducts.com.au](http://www.mhaproducts.com.au) for more images and details

## ABOUT MHA PRODUCTS

At Manual Handling Australia (MHA), we have the largest range of manual handling and workplace materials handling equipment in Australia. This includes thousands of workplace and storage items suited to every workplace and lifting equipment and trolleys for almost every application. Our products aim to eliminate or reduce manual handling effort in the workplace, while boosting productivity and ensuring workplace safety.

MHA has over many years spent countless hours on product development and sourcing to ensure we can get products to make your workplace not only safer but more efficient.

MHA sources products from all over the world and sells them direct meaning there is no middle man or middle margin added giving you the best possible price and faster service. We also offer customised solutions with trolleys, lifters and many other materials handling equipment to ensure you have the perfect product to improve the safety and efficiency of your workplace.

MHA is dedicated to providing you with the highest quality products at the best possible price, with the best possible service. With a long and trusted reputation in the industry, MHA is a name you can rely on.