

MHA PRODUCTS

MATERIALS HANDLING & STORAGE EQUIPMENT

 www.mhaproducts.com.au

TAX TIME SAVINGS

On sale until June 30th 2022



X-CART

Folding Aluminum Trolley

The X-cart is a collapsible trolley that can be used for hundreds of applications. It can be completely collapsed by the push of a button on the handle. Comes with one collapsible basket. Extra baskets are available. T9000

NOW \$249
SAVE \$146

See page 3

TROLLEYS & HAND TRUCKS · LIFTING & ELEVATING · CONVEYOR · ACCESS · DRUM HANDLING · CONTAINMENT & SPILLAGE · WASTE HANDLING · SHELVING & STORAGE · WORKPLACE & OFFICE · PLASTIC BINS & CRATES · SAFETY · CONSTRUCTION · MEDICAL & HOSPITAL SUPPLIES · CUSTOM MANUFACTURING



NOW \$2,725
SAVE \$340

Liftex Electric Work Positioner M2190

See page 17



Verdex Quad Deck Tool Cart (with tool board) M1466

NOW \$615
SAVE \$80

See page 7



Stormax Lockable Storage Cage AS8052

NOW \$880
SAVE \$112

See page 22



Bishamon Pneumatic Rotating Pallet Positioner B1030

NOW \$5,089
SAVE \$644

See page 16



Verdex 40L Manual Floor Sweeping Machine WS9000

NOW \$744
SAVE \$94

See page 32



Liftex Crane / Forklift Spreader Beam FL2439

NOW \$2,257
SAVE \$283

See page 18

FREE GIVEAWAYS

Available with every order over \$500. Scan QR code for more details online.





Stormax Galvanised Mesh Cage SC750

NOW \$385
SAVE \$50

See page 28



Durolla 3 Step Ladder Trolley T6100

NOW \$1,315
SAVE \$172

See page 4



Liftex 500kg Scissor lift trolley LT8703

NOW \$705
SAVE \$91

See page 13



Stormax Industrial cabinet with 2 drawers M7211

NOW \$1,205
SAVE \$154

See page 31

WE HAVE THE LARGEST RANGE OF MANUAL HANDLING & WORKPLACE MATERIALS HANDLING EQUIPMENT IN AUSTRALIA

BIGGEST RANGE IN AUSTRALIA

Shop Online



 www.mhaproducts.com.au
 sales@mhaproducts.com.au
 **1800 750 900**

Multi Purpose Platform Convertible Tiered Trolley



- 3 options available with this configurable platform trolley.
- Bolt together steel construction (supplied flatpack)
- Powder coated blue
- Rubber castors - 2 x fixed, 2 x swivel with brakes
- Load Capacity: 500kg (top shelf capacity on M1852 is 200kg)
- Castors: 160mm
- Handle Height: 1000mm
- Shelf Size: 1100x600mm
- Shelf Heights: 230 + 720mm
- Overall Size (LxWxH): 1320x600x1000mm
- Unit Weight: 48kg



Code	Details	WAS	NOW
M1850	Single Handle Platform Trolley 600x1320mm	\$593	\$523
M1860	Double Handle Platform Trolley 600x1320mm	\$683	\$599
M1862	Double Handle 2 Tier Trolley 600x1320mm	\$908	\$795
T3191	Clipboard Holder Attachment to suit	\$98	\$85
T3192	Laptop Holder Attachment to suit	\$98	\$85
M1843	Mesh Basket Accessory Tray to suit M1850	\$85	\$75

X-Cart Folding Trolley (Includes 1 basket)

- The X-Cart is a collapsible trolley that can be used for hundreds of applications.
- It can be completely collapsed by the push of a button on the handle. The wheels are able to be removed by the push of a button and stored underneath for compact transport and storage.
- The X-Cart is supplied with one collapsible basket which will lock into place on either the top or bottom platform. The top platform can be folded back to allow larger items to be transported if required.
- Extra baskets are available for use on both platforms or up to 4 baskets can be stacked on the bottom platform.
- A robust foot pedal brake allows the X-Cart to be locked in position whilst loading or unloading.
- The injection moulded plastic and aluminium design means that whilst the X-Cart is lightweight it is still very robust and has a great carrying capacity.
- The basket fits fooscap suspension files, which is great for transporting documents throughout the office.
- The X-Cart can also be used with our standard No.7, No.10 and No.15 tubs.

Specifications

- Total Trolley Capacity: 90kg
- Top Shelf Capacity: 40kg
- Bottom Shelf Capacity: 50kg
- Trolley Weight: 10kg
- Basket Weight: 1.8kg
- Handle Height: 1050mm

Dimensions

- Overall Size Assembled (LxWxH): 1000x600x1070mm
- Overall Size Folded (LxWxH): 740x540x105mm
- Internal Basket Size (LxWxH): 525x365x255mm
- External Basket Size (LxWxH): 560x400x260mm



Code	Details	WAS	NOW
T9000	X-Cart Folding Plastic & Aluminium Trolley	\$395	\$249
T9010	X-Cart Vinyl Cover	\$135	\$98
T9020	X-Cart Tool Bin	\$48	\$39
T9030	Hard Lid to suit X-Cart Basket	\$49	\$39
T9050	Extra basket for X-Cart Trolley	\$45	\$35

X-CART

3 Tier Service Trolley

- These utility carts have polypropylene side panels which keep the load more secure on the trolley
- Rubber castors - 2 x swivel, 2 x swivel with brakes
- Load Capacity: 250kg
- Castors: 100mm
- Tray Size: 680x450mm
- Overall Size (LxWxH): 870x500x1010mm
- Unit Weight: 15kg



Code	WAS	NOW
M1455	\$385	\$339

VERDEX

Extra Long 3 Tier Service Trolley

- These utility carts have polypropylene side panels which keep the load more secure on the trolley
- Rubber castors - 2 x swivel, 2 x swivel with brakes
- Load Capacity: 250kg
- Castors: 100mm
- Tray Size: 920x520mm
- Overall Size (LxWxH): 1110x520x1010mm
- Unit Weight: 21kg



Code	WAS	NOW
M1456	\$495	\$439

VERDEX

All Terrain Platform Trolley

- The All Terrain Platform Trolley is perfect for construction sites and general warehouse use
- Heavy duty trolley construction
- Handle activated brake
- Swivel handle for steering the trolley
- Powder coated frame with plywood deck
- Optional sides available (M1064)
- 4 x pneumatic wheels with steel rim
- Load Capacity: 1300kg
- Castors: 300mm
- Overall Size (LxWxH): 1200x690x397mm
- Unit Weight: 49kg



M1063 pictured with M1064



Durolla™

Code	Details	WAS	NOW
M1063	All Terrain Platform Trolley	\$1,535	\$1,365
M1064	Optional Sides to suit M1063	\$249	\$219

3 Step Ladder Trolley

- Strong 3 step ladder which folds up when not required
- Great for picking stock when you need to reach up high
- Middle shelf has 3 shelf positions
- Ladder is connected with the brake to stop wheels turning which enhances security when using the ladder
- Anti-slip steps which ensure safe operation
- Polyurethane castors - 2 x fixed, 2 x swivel with brakes
- Load Capacity: 400kg
- Castors: 100mm
- Platform Size: 700x500mm
- Overall Size (LxWxH): 1125x525x1110mm
- Unit Weight: 45kg



Durolla™

Code	WAS	NOW
T6100	\$1,487	\$1,315



Transport Trolley with Storage Basket

- Ideal for transporting large and bulky items on rough ground due to the pneumatic wheels
- Construction trolley with steel tubular frame and heavy duty plywood base
- Handy basket for storage of small items
- Very manoeuvrable due to the centre wheels
- 2 x swivel rubber castors with brake
- 2 x pneumatic fixed centre wheels
- Load Capacity: 500kg
- Pneumatic Castors: 260mm
- Rubber Castors: 200mm
- Platform Height: 320mm
- Overall Size (LxWxH): 1000x700x1250
- Unit Weight: 36kg



Code	WAS	NOW
M1248	\$587	\$519

3 Tier Utility Service Trolley

- Heavy duty plastic construction which resists dents, chips and rust
- Polypropylene handles with aluminium frames
- Sturdy and stable but lightweight making it easy to manoeuvre
- Rubber castors - 2 x swivel, 2 x swivel with brakes
- Load Capacity: 180kg
- Castors: 75mm
- Tray Size: 485x365mm
- Overall Size (LxWxH): 660x380x900mm
- Unit Weight: 6kg



Code	WAS	NOW
M1451	\$189	\$169

VERDEX

Nestable Stock Trolley

- The Nestable Stock Trolley is ideal for transporting heavy boxes and other product, due to its wide surface area and high quality construction.
- This trolley is the perfect addition to any supermarket store or factory where numerous goods need to be stacked or moved frequently with ease
- Electro galvanised construction and powder coated handles
- Rubber castors - 4 x swivel
- Load Capacity: 200kg
- Castors: 125mm
- Platform Size: 600x850mm
- Overall Size (LxWxH): 1170x700x980mm
- Unit Weight: 22kg



Code	WAS	NOW
M1260	\$877	\$599



Mesh Trolley with Folding Lid & Side

- The Mesh Trolley is able to hold many items safely and securely due to the attached lid.
- Foldable side and lid for easy access to products
- Comes with a padlock hasp which allows the trolley to be securely locked when not in use
- Mesh Size: 50x50mm
- Electro galvanised finish
- Polyurethane castors - 2 x swivel with brakes, 2 x swivel
- Load Capacity: 150kg
- Castors: 100mm
- Overall Size (LxWxH): 1180x662x858mm
- Unit Weight: 28kg



Code	WAS	NOW
M1682	\$477	\$423

Service Cart with Side Rails

- Lightweight trolley yet very robust design ideal for multiple uses
- Electro galvanised finish
- Rubber castors - 2 x swivel, 2 x swivel with brake
- Load Capacity: 250kg
- Castors: 125mm
- Distance between shelves: 325mm
- Height to Top Shelf: 705mm
- Shelf Size (LxWxH): 935x535x90mm
- Overall Size (LxWxH): 1130x550x940mm
- Unit Weight: 24kg



Code	WAS	NOW
M1037	\$589	\$524

Heavy Duty Aluminium Platform Trolley

- Lightweight and corrosion resistant
- Highly maneuverable heavy duty construction
- Checker plate deck
- Removable handles (option of 1 or 2 handles) available online
- 150mm polyurethane castors - 2 fixed & 2 swivel with brakes
- Load Capacity: 500kg
- Handle Height: 1010mm
- Platform Height: 260mm
- Supplied flatpack (can be assembled on request
*additional charges may apply)
- Optional pneumatic wheel kit available online
- Platform Size: 1230x620mm
- Unit Weight: 25kg

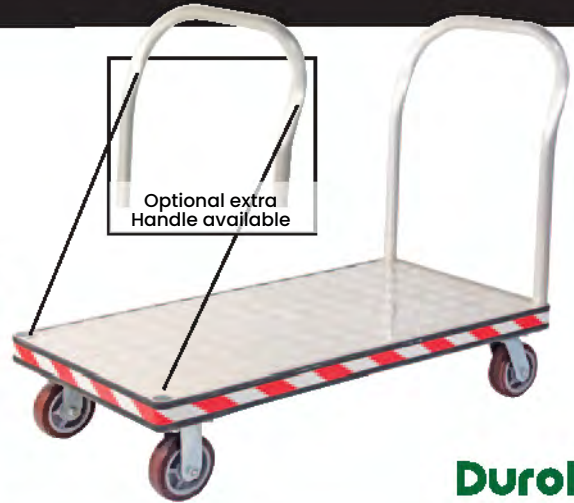

Durolla™

Code	WAS	NOW
17261	\$805	\$715

Folding Aluminium Hand Trucks

- Great lightweight hand trucks for general load carting
- Folds completely flat as pictured
- 2 load capacities available
- The M1178 trolley has a clip on attachment to fit the X-Cart folding basket

VERDEX



The M1178 trolley fits the X-Cart folding crate (see page 3)



Code	Details	Open Size (LxWxH)	Folded Size (LxWxH)	Unit Weight	WAS	NOW
M1177	Folding Hand Truck 125kg Load Capacity	500x520x1070mm	490x65x770mm	7.5kg	\$195	\$165
M1178	Folding Hand Truck 68kg Load Capacity	400x400x1000mm	385x55x635mm	14.5kg	\$165	\$139

Heavy Duty Appliance Trolley

- Industrial quality hand trolley to suit a variety of applications
- Flat free tyres
- Load Capacity: 220kg
- Foot Size (WxD): 470x175mm
- Depth: 720mm
- Width: 500mm
- Height: 1260mm
- Unit Weight: 18kg



Durolla™

Code	WAS	NOW
M1254	\$420	\$372

150kg Aluminium Hand Trolley

- Great lightweight hand truck for general load carting
- Pneumatic tyres
- Load Capacity: 150kg
- Castors: 260mm
- Foot Plate Size (WxD): 355x180mm
- Overall Size (WxDxH): 520x470x1260mm
- Unit Weight: 10kg



Durolla™

Code	WAS	NOW
T8473	\$192	\$169

Heavy Duty Panel Rack Cart

These powder coated panel carts are ideal for moving large bulky goods including, timber sheets, plasterboard, mattresses etc.

- Middle divider post can be removed
- Space Between Bars: 310mm
- Polyurethane castors - 2 x fixed, 2 x swivel with brakes
- Load Capacity: 2000kg
- Castors: 125mm
- Platform Height: 220mm
- Platform Size: 770x915mm
- Overall Size (LxWxH): 770x915x970mm
- Unit Weight: 79kg



Code	WAS	NOW
T8667	\$773	\$687

Durolla™

A Frame Panel Cart

- These powder coated panel carts are ideal for moving large bulky goods including, timber sheets, plasterboard, mattresses etc.
- Polyurethane castors - 2 x fixed, 2 x swivel with brakes
- Load Capacity: 1000kg
- Castors: 125mm
- Platform Height: 230mm
- Platform Size: 1830x815mm
- Overall Size (LxWxH): 1915x920x1400mm
- Unit Weight: 120kg



Code	WAS	NOW
T8668	\$907	\$805

Durolla™

Quad Deck Tool Cart

- Excellent tool cart with square hole pegboard
- Supplied with accessories
- Tray depth: 50mm
- Nylon castors - 2 x swivel, 2 x swivel with brakes
- Load Capacity: 300kg
- Castors: 100mm
- Platform Heights: 170 + 370 + 570 + 770mm
- Shelf Size: 585x405mm
- Overall Size (LxWxH): 690x430x1215mm
- Unit Weight: 24kg
- Accessories Supplied: 5 x hooks; 2 x T-Handle Rack, 2 x Plastic trays



VERDEX

Code	WAS	NOW
M1466	\$695	\$615

Triple Shelf Basket Trolley

- Great for storing small parts and items neatly in the office
- Supplied with plastic baskets as pictured
- Integrated frame handles
- Quality swivel castors 2 with brakes
- Load Capacity: 50kg
- Castor Size: 100mm
- Shelf Size: 500x400mm
- Overall Size (LxWxH): 520x470x1085mm
- Unit Weight: 11kg
- Plastic Basket Size (LxWxH): 510x360x200mm



VERDEX

Code	WAS	NOW
M1525	\$275	\$244

3 Tier Stainless Steel Trolley

- Heavy duty stainless steel 3 tier trolleys are great for use in hospitality areas.
- The shelves can be used as a flat platform or turned upside down and used as a tray
- Polyurethane castors- 4 x swivel
- 304 grade Stainless Steel
- Overall Length Including Handle: 750mm
- Load Capacity: 200kg
- Castors: 100mm
- Handle Height: 910mm
- Distance Between Trays: 10mm
- Tray Size (WxDxH): 600x400x50mm
- Platform Size (WxL): 655x400mm
- Unit Weight: 18kg



Durolla™

Code	WAS	NOW
ST630	\$598	\$529

Prestige 2 Tier Trolley

Heavy duty steel trolleys which are great for dozens of uses in warehouses, schools, hospitals etc.

- Powder coated steel construction
- Chrome steel handle with plastic end caps
- The shelves can be used as a flat platform or turned upside down and used as a tray
- Polyurethane castors - 2 x fixed, 2 x swivel
- Load Capacity: 200kg
- Castors: 100mm
- Handle Height: 890mm
- Shelf Size: 750x500mm
- Overall Size (LxWxH): 830x500x930mm
- Unit Weight: 295kg



Durolla™

Code	WAS	NOW
T0255	\$295	\$260



3 Tier Multi Shelf Trolleys

- 3 Tiered Multi Shelf Trolley is ideal for order picking and transporting goods in the workplace
- Suitable for use in retail and industrial applications
- The shelves can be used as a flat platform or turned upside down and used as a tray
- Powder coated finish
- Available in Blue or White
- Overall Size: 1080x480x940mm (LxWxH)
- Rubber Castors - 2 x swivel, 2 x swivel with brakes
- Load Capacity: 250kg
- Castors: 125mm
- Shelf Size: 900x440mm
- Distance Between Shelves: 250mm
- Height To Top Shelf: 760mm
- Unit Weight: 30kg



M1660



M1661

Code	Details	WAS	NOW
M1660	Blue 3 Tier Multi Shelf Trolley	\$520	\$459
M1661	White 3 Tier Multi Shelf Trolley	\$520	\$459

Computer Carts

- These computer carts are great for both office and warehouse use
- Both come with a slide out keyboard tray
- Quality swivel castors (2 with brakes)
- Castor Size: 100mm
- Load Capacity: 250kg
- Castors: 100mm



M1470



M1472

VERDEX

Code	Details	Overall Size (LxWxH)	Shelf Size	Unit Weight	WAS	NOW
M1470	3 Tier Aluminium Framed Computer Cart	810x510x1160mm	620x450mm	18kg	\$395	\$349
M1472	3 Tier Steel Computer Cart (with shelf)	610x520x910mm	610x460mm	28kg	\$485	\$429

3 Tier Stainless Steel Trolley

- Rubber corner protectors as standard
- Rubber castors - 2 x swivel, 2 x swivel with brakes
- Load Capacity: 150kg
- Castor Size: 100mm
- Handle Height: 960mm
- Shelf Size (LxW): 900x500mm
- Shelf Heights: 200 + 510 + 820mm
- Overall Size (LxWxH): 1010x560x960mm
- Unit Weight: 15kg



Code	WAS	NOW
ST673	\$387	\$342

Durolla™

Double Gas Cylinder Trolley

- This gas cylinder trolley is ideal for transporting two cylinders
- Heavy duty solid 390mm rubber wheels
- Supplied with securing chains as pictured
- Suits 2 gas bottles with diameter of 140-250mm
- Overall Size (WxDxH): 700x700x1380mm
- Unit Weight: 44kg



Durolla™

Code	WAS	NOW
T2002	\$480	\$425

Multi-Purpose Cage Trolleys

- Industrial quality trolleys with cage stop goods falling off the platform.
- The cage has fold down sides for easy loading and unloading
- Powder coated steel construction with vinyl platform
- Surround bumper on perimeter of trolley
- Ergonomically designed with handle at optimum height
- Polyurethane castors - 2 x fixed, 2 x swivel
- Load Capacity: 220kg
- Castors: 100mm
- Handle Height: 1000mm
- Platform Size: 710x450mm
- Platform Height: 140mm
- Overall Size (LxWxH): 820X490X1000mm
- Unit Weight: 19kg



Durolla™

Code	WAS	NOW
T9324	\$390	\$344

Steel Box Trolley (with fold down sides)

- Great for stock picking in the warehouse or for linen collection in hospitals and nursing homes
- Front folds down for easy access to goods while loading and unloading
- Quality castors for smooth and effortless moving
- Quality powdercoated finish
- Load Capacity: 500kg
- Castors: 150mm
- Handle Height: 850mm
- Internal Size (LxWxH): 1040x640x630mm
- Overall Size (LxWxH): 1200x720x850mm



Code	WAS	NOW
T5203	\$1,245	\$928

Durolla™

2 Tier Picking Trolley

- Rubber lined shelves to help stop items from sliding off when moving around
- Wire tool basket supplied as standard which is great for tool and scanner storage
- Fully welded steel construction
- Powder coated blue
- Supplied standard with 4 swivel castors - 2 with brakes
- Load Capacity: 500kgs
- Castors: 125mm
- Handle Height: 1055mm
- Shelf Size: 910x610mm
- Shelf Heights: 190 + 880mm
- Overall Dimensions (LxWxH): 1080x610x1055mm
- Basket Dimensions (LxWxH): 265x145x170mm
- Distance between Shelves: 655mm
- Unit Weight: 39kg



Code	WAS	NOW
T8684C	\$995	\$883

Durolla™

Plastic X Shape Laundry Cart

- Lightweight trolley which is great for carting linen or waste
- Easily remove the waste bag by unhooking from the frame
- Can be folded when not in use
- Strong vinyl bag
- Load Capacity: 60kg
- Volume Capacity: 178 Litre
- Castors: 75mm
- Folded Size (LxWxH): 660x440x1100mm
- Overall Size (LxWxH): 690x660x950mm
- Unit Weight: 10kg



VERDEX

Code	WAS	NOW
T9070	\$177	\$155

Plastic Tub Trolleys & Tubs

- Heavy duty rotomoulded tub with 25mm steel tubular frame
- Internal Base Dimension (WxL): 500x780mm
- Internal Top Dimension (WxL): 615x910mm
- Outer Rim Dimension (WxL): 740x1045mm
- Height From Ground To Top Rim: 740mm
- Nylon castors - 2 x fixed, 2 x swivel
- Load Capacity: 400kg
- Bin Capacity: 400L
- Castors: 100mm
- Handle Height: 780mm
- Tubs are ribbed for extra strength
- Tubs available to buy separate from the Tub Trolley



T1130W



T1125

Code	Details	Overall Size (WxDxH)	Unit Weight	WAS	NOW
T1125	White Tub with Trolley	1200x740x780mm	25kg	\$590	\$525
T1130W	White 400L Tub	see description above	8.5kg	\$395	\$348

VERDEX

Heavy Duty Goods Trolley with Shelf

- An extremely versatile goods cage with the space saving benefit of being able to be collapsed easily for storage when not in use.
- Fitted with a fold up upper shelf and 270 degree opening lockable gates, this cage can be used in a single or a two shelf configuration.
- Powder coated finish
- Lower Shelf Height Space: 780mm
- Upper Shelf Height Space: 700mm
- Lower Shelf Height: 205mm
- Upper Shelf Height: 1010mm
- Rubber castors – 2 x swivel, 2 x swivel with brakes
- Load Capacity: 500kg
- Castors: 125mm
- Shelf Size: 1030x750mm
- Overall Size (LxWxH): 1100x800x1700mm
- Unit Weight: 90kg

Durolla™



Trolley can be folded for nesting when not in use



2 door configuration is ideal for moving different products

Code	WAS	NOW
T4975V	\$1,068	\$946

Heavy Duty Sloping 4 Shelf Trolleys

- Heavy duty bolt together trolley which is great for stock picking
- 4 backwards sloping shelves which prevents items falling off
- Shelves are removable but not adjustable
- Shelves have 10° decline
- 350mm space between each shelf
- Push/pull handles on each end
- Rubber castors: 2 fixed, 2 swivel with brakes
- Load Capacity: 500kg
- Castors: 150mm

Durolla™



Shelves are reinforced underneath for extra strength



19344



19345

Code	Shelf Size (mm)	Overall Size LxWxH (mm)	Unit Weight (kg)	WAS	NOW
19344	1160x580	1410x620x1770	94	\$1,258	\$1,115
19345	1460x730	1730x770x1770	122	\$1,497	\$1,327

Single Tub Order Picking Trolley

- Fully welded steel construction
- Powder coated finish
- Rubber castors - 2 x swivel, 2 x swivel with brakes
- Load Capacity: 250kg
- Castors: 125mm
- Overall Size (LxWxH): 730x420x1000mm
- Unit Weight: 10kg
- Optional accessories available including clipboard holder, laptop holder and tool basket (see online)



Image shown with No.10 plastic tub, which is sold separately to the trolley. There is 3 different size tubs in 6 different colours. Please visit our website and search code 10410 for options. No.7, No.10 and No.15 fit this trolley.

Code	WAS	NOW
T3090	\$399	\$339

Durolla™

Double Tub Order Picking Trolley

- Fully welded steel construction
- Powder coated finish
- Rubber castors - 2 x swivel, 2 x swivel with brakes
- Load Capacity: 250kg
- Castors: 125mm
- Overall Size (LxWxH): 920x680x890mm
- Unit Weight: 19kg
- Optional accessories available including clipboard holder, laptop holder and tool basket (see online)



Image shown with No.10 plastic tubs, which are sold separately to the trolley. There is 3 different size tubs in 6 different colours. Please visit our website and search code 10410 for options. No.7, No.10 and No.15 fit this trolley.

Code	WAS	NOW
T3091	\$499	\$426

Durolla™

Twin Offset Tub Order Picking Trolley

- Fully welded steel construction
- Powder coated finish
- Rubber Castors - 2 x swivel, 2 x swivel with brakes
- Load Capacity: 250kg
- Castors: 125mm
- Overall Size (LxWxH): 1050x450x1300mm
- Unit Weight: 15kg
- Optional accessories available including clipboard holder, laptop holder and tool basket (see online)



Image shown with 2 No.10 plastic tubs, which are sold separately to the trolley. There are 3 different size tubs in 6 different colours. Please visit our website and search code 10410 for options. No.7, No.10 and No.15 fit this trolley.

Code	WAS	NOW
T3094	\$495	\$438

Durolla™

Order Picking Trolley Accessories



M1843 - Mesh Basket Accessory Tray



T3191 - Clipboard Holder Attachment



T3192 - Laptop Holder Attachment

FOR PRICING SEE ONLINE

Order Picking Trolleys suit these 3 size tubs

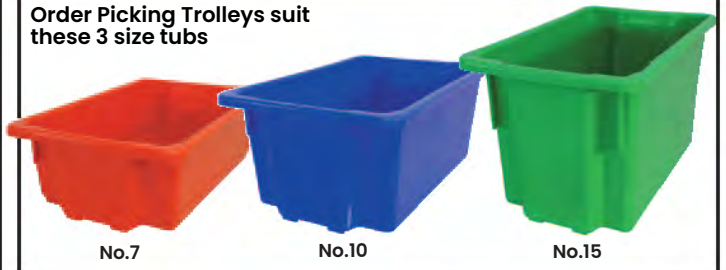

No.7

No.10

No.15

750kg Equipment Roller Skates

- Ideal for linear motion, repetitive movement or use as a built in component in equipment
- Fixed hole pattern for bolt mounting
- The rollers can be used in up down or sideways position
- Load Capacity: 750kg
- Overall Size (LxWxH): 165x178x80mm
- Unit Weight: 5kg



Code	WAS	NOW
RS750	\$163	\$140

LIFTEX

2,500kg Shifting Skates

- These shifting skates can be used wherever heavy objects need to be moved
- Large diameter nylon rollers ensure ease of movement and spread the load to protect floors from damage caused from high load points
- Fitted with a rubber surface to protect the objects being moved
- Load Capacity: 2,500kg
- Castors: 2x85mm
- Overall Size (LxWxH): 210x100x105mm
- Unit Weight: 4kg



Code	WAS	NOW
SS2000	\$193	\$170

LIFTEX

Powered Platform Trolley (with cage)

- Also comes with a removable Guard Rail (as pictured) to avoid items from falling out
- Platform has an anti-slip grip so that items dont slide off easily in transit
- Rubber bumper edge
- Emergency stop button
- Comes with forward and reverse drive option
- Variable speed controller
- Batteries: 2 x 12V / 33Ah batteries
- Clearance from battery box to ground: 65mm
- Cage Depth: 600mm
- Moving Speed: 5-8km/h
- Load Capacity: 400kgs
- Front Wheels: 260mm
- Rear Castors: 150mm
- Handle Height: 1080mm
- Platform Size (WxL): 1290x640mm
- Platform Height: 320mm
- Overall size (LxWxH): 1420x630x1090mm
- Unit Weight: 110kg

LIFTEX



Code	WAS	NOW
T9302	\$3,110	\$2,765

Powered Dump Trolley

- Great for dirt, bark and rubbish removal in outdoor areas
- Emergency stop button
- Comes with forward and reverse drive options
- Variable speed controller
- Powered by 3 x 12V / 55Ah batteries
- Load Capacity: 800kgs
- Wheel Size: 325mm (pneumatic)
- Moving Speed: 5-8km/h
- Lift Time: 15 secs
- Lift Angle: 45 degrees
- Tray Size (LxWxH): 1510x800x310mm
- Overall Size (LxWxH): 2250x810x1070mm
- Unit Weight: 250kg

LIFTEX



Code	WAS	NOW
T9310	\$5,985	\$5,325

Electric Scissor Lift Trolley with Removable Cage

- These self propelled lift tables reduce the need to push heavy items manually as well as having electric operated lift.
- With the centre drive wheel it makes it extremely easy to manoeuvre loads.
- Comes complete with a removable side cage
- 4 x swivel castors with brakes
- 2 x pneumatic centre drive wheels
- Batteries: 2x12V 33Ah
- Curtis Controller: 70A
- Motor (Driving): 400W
- Motor (Lifting): 400W
- Lifting Time: 17 seconds
- Load Capacity: 400kg
- Castors: 150mm
- Middle Wheels: 275mm
- Table Size: 1000x600mm
- Lifting Range: 460-900mm
- Cage Height: 600mm
- Overall Size (LxWxH): 1240x600x1100mm
- Unit Weight: 180kg



Code	WAS	NOW
LT7240	\$6,282	\$5,585

LIFTEX

300kg Electric Double Scissor Lift Trolley

- Self Propelled Double Electric Scissor lift is optimal for reaching high spaces
- 2 x rear swivel castors with brake
- 2 x pneumatic drive wheels
- Batteries: 2x12V 33Ah
- Curtis Controller: 70A
- Motor (Driving): 400W
- Motor (Lifting): 400W
- Lifting Time: 17 seconds
- Load Capacity: 400kg
- Rear Castors: 150mm
- Front Wheels: 275mm
- Table Size: 1100x600mm
- Lifting Range: 460-1600mm
- Overall Size (LxWxH): 1340x660x1100mm
- Unit Weight: 234kg



LIFTEX

Code	WAS	NOW
LT7440	\$5,838	\$5,190

Galvanised Scissor Lift Trolley

- Galvanised version is great for food and medical areas
- Foot operated hydraulic operation
- Lever release control
- Double scissor lift version
- Safety overload bypass valve
- Steppless rate of lowering regardless of load weight
- Polyurethane castors - 2 x fixed, 2 x swivel with brakes
- Load Capacity: 150kg
- Castors: 100mm
- Table Size: 500x830mm
- Lifting Range: 435-1430mm
- Unit Weight: 80kg



LIFTEX

Code	WAS	NOW
LT8706	\$1,245	\$1,105

Scissor Lift Trolleys (Foot Pedal Operated)

- These units help take the strain out of loading and unloading items from raised levels.
- The table is elevated by a pump action foot pedal and smoothly lowered by a hand operated release trigger.
- Foot operated hydraulic operation
- Lever release control
- Safety overload bypass valve
- Durable powder coated finish
- Polyurethane castors - 2 x fixed, 2 x swivel with brakes
- Castors: 125mm



LT8702



LT8703



LT8707



LT8708

Code	Capacity	Details	Platform Size	Min Height	Max Height	Unit Weight	WAS	NOW
LT8702	300kg	Single Scissor	500x850mm	340mm	900mm	77kg	\$759	\$670
LT8703	500kg	Single Scissor	500x850mm	340mm	850mm	81kg	\$796	\$705
LT8707	500kg	Double Scissor	520x1010mm	440mm	1615mm	168kg	\$1,089	\$965
LT8708	750kg	Single Scissor	510x1000mm	435mm	1000mm	175kg	\$1,135	\$998

LIFTEX

300 kg Electric Scissor Lift Trolley

- Smooth lifting of heavy loads with ease
- Automatic 12v charger
- Push button, battery/hydraulic operation
- Polyurethane castors - 2 x fixed, 2 x swivel with brakes
- Load Capacity: 300kg
- Castors: 125mm
- Table Size: 850x500mm
- Lifting Range: 290-880mm
- Unit Weight: 115kg



Code	WAS	NOW
LT7230	\$3,599	\$3,196

LIFTEX

500kg Electric Scissor Lift Trolley

- Smooth lifting of heavy loads with ease
- Automatic 12v charger
- Push button, battery/hydraulic operation
- Polyurethane castors - 2 x fixed, 2 x swivel with brakes
- Load Capacity: 500kg
- Castors: 150mm
- Table Size: 1010x520mm
- Lifting Range 495-1618mm
- Unit Weight: 198kg



LIFTEX

Code	WAS	NOW
LT7233	\$3,725	\$3,305

Rough Terrain Scissor Lift Trolley

- Rough terrain scissor lift trolley is ideal for outdoor applications
- Foot Pedal Cycles to Max Height: 25
- Durable powder coated finish
- Rubber castors - 2 x fixed, 2 x swivel with brakes
- Load Capacity: 200kg
- Castors: 200mm
- Table Size: 1000x500mm
- Lifting Range: 340-1010mm
- Unit Weight: 71kg



Code	WAS	NOW
LT8712	\$1,085	\$962

LIFTEX

Pallet Truck with Load Scales

- The weighing unit uses four AA batteries which give approx 4200 weighting actions
- The unit gives a low battery warning and shuts off after 3 minutes
- The digital display can be read from any angle in ambient light conditions
- Scale Increments: 1kg
- Scale Functions: Zero correction, gross/net weight, total weight
- Load Capacity: 2000kg
- Steering Wheel Size: 50x180mm
- Tine Size: 50x182mm
- Overall Fork Length: 1150mm
- Width: 690mm
- Minimum Fork Height: 76mm
- Unit Weight: 113kg

LIFTEX



Code	WAS	NOW
T7221	\$2,480	\$2,205

Low Profile Electric Pallet Lift Tables

- Many applications require the regular loading and unloading of palletised goods.
- Using pallet lift tables elevates pallets to the optimum lift height reducing the risk of repetitive strain injury and increasing productivity.
- Supplied with entry ramp to allow pallet truck entry
- Tables are specially made for handling pallets, no need for a pit or load ramps
- Upper platform fitted with safety perimeter to prevent descent on contact with obstructions
- 24v control box with UP and DOWN buttons and emergency stop
- External power pack equipped with a relief valve against overloading and a compensating flow valve for controlling lowering speed
- Power Supply: 240v (3 phase 415v available if required)
- Hose burst safety valve to stop the lift table lowering in case of hose breakage
- Removable lifting eyes to facilitate handling and installation of the lift table
- Oil-less bushings on pivot points



LIFTEX

Code	Load Capacity (kg)	Platform Size (mm)	Lifting Range (mm)	Lift Time	Unit Weight (kg)	WAS	NOW
LT7250	1000	1140x1420	85-880	25 secs	357	\$4,890	\$4,344
LT7252	2000	1180x1600	105-880	25 secs	419	\$6,654	\$5,920

The Edge - Electric Pallet Truck

- The economical option for an electric pallet truck - avoid the strain of manually pushing a pallet standard pallet truck.
- Capacity up to 1500 kg and ability to overcome ramps up to 4/16% (loaded/unloaded) makes the truck suitable for work in loading docks and on delivery operations in different conditions
- Load Capacity: 1500kgs
- Tine Size: 60x142x1070mm
- Length of Tines: 1185mm
- Overall Size (LxW) : 1530x685mm
- Min Fork Height: 85mm
- Lowered Height: 80mm
- Unit Weight: 123kg
- Wheel Type: Polyurethane
- Travel Speed (unloaded): 5.8 Km/h
- Electric Brake
- Battery: 24V 20Ah
- Brushless AC motor
- Emergency stop button
- Unit Weight: 123kg
- Extra Battery Weight: 4.6kg



LIFTEX

Code	Details	WAS	NOW
SA721	The Edge - Electric Pallet Truck 1500kg (supplied with 1 battery)	\$3,895	\$3,459
SA721B	The Edge - Additional Battery 24V 20Ah	\$640	\$568

2500kg Powdercoated Pallet Truck

- A Pallet Truck is a tool used to lift and move pallets.
- Pallet jacks are the most basic form of a forklift and are intended to move heavy or light pallets within a warehouse
- Load Capacity: 2500kg
- Tine Size: 50x160mm
- Fork Length: 1150mm
- Overall Size (WxL): 685x1500mm
- Min Height: 85mm
- Unit Weight: 70kg



Code	WAS	NOW
PT7203	\$475	\$422

LIFTEX

Low Profile Pallet Truck

- Easy access into low skids and pallets.
- Great for unloading containers with low import type pallets with a low clearance of only 51mm.
- Powdercoated safety yellow
- Load Capacity: 1500kg
- Steering Wheel Size: 50x180mm
- Tine Size (LxWxH): 1150x160x37mm
- Overall Size (LxW): 1550x685mm
- Min Fork Height: 51mm
- Unit Weight: 80kg



LIFTEX

Code	WAS	NOW
PT8619	\$845	\$748

Stainless Steel Pallet Trucks

- These Stainless steel pallet trucks are available in both standard size 685mm wide and Euro pallet size 520mm
- Ideal for the food, chemical and pharmaceutical industry or where corrosive acids are used
- Front wheels are fully enclosed which is a required for clean rooms and food environments
- Nylon Wheels
- Steering Wheel Size: 50x200mm
- Nylon wheels
- Load Capacity: 2000kg
- Tine Size: 60x160mm
- Length: 1150mm
- Min. Fork Height: 85mm



LIFTEX

Code	Details	Width	Unit Weight	WAS	NOW
PT7215	Stainless Steel Pallet Truck (Euro Size)	520mm	75kg	\$3,995	\$2,998
PT7214	Stainless Steel Pallet Truck (Standard Size)	685mm	77kg	\$3,995	\$2,998

Extra Long Pallet Trucks

- These extra long pallet trucks are extremely useful for extra deep pallets.
- Also can be used to pickup two pallets in one lift.
- Tine Size: 60x160mm
- Steering Wheel Size: 50x200mm
- Powdercoated safety yellow
- Polyurethane wheels as standard



LIFTEX

Code	Details	Load Capacity	Width	Unit Weight	WAS	NOW
PT9065	Extra Long Pallet Truck (1800mm long forks)	2000kg	685mm	110kg	\$1,160	\$1,029
PT9067	Extra Long Pallet Truck (1800mm long forks)	2000kg	520mm	100kg	\$1,195	\$1,060

Galvanised Pallet Elevator with Pallet Truck Base

- The pallet elevator keeps the active layer of the load at or above waist height, eliminating bending and lifting.
- This pallet elevator can be moved with a standard Pallet Truck
- It is proving highly effective at reducing the incidences of repetitive strain and back injury.
- The construction of the pallet elevator is a scissor type action with varying springs which can be adjusted for different heights
- Turntable allows the operator to rotate the load with minimal stretching and reaching.
- No ground fixing required
- Galvanised finish
- Load Capacity: 2000kg
- Table Diameter: 1110mm
- Low Height: 315mm
- Max Height: 790mm
- Fork Pocket Centres: 615mm
- Fork Pocket Size: 300x90mm
- Unit Weight: 195kg

View video of this in operation here,
www.mhaproducts.com.au/M2135



M2135 pictured with a Pallet Truck

Code	WAS	NOW
M2135	\$2,570	\$2,285



Bishamon Pneumatic Rotating Pallet Positioner (For varying pallet weights)

The most advanced pallet positioner available!

- EZ Loaders are designed to eliminate worker bending by automatically raising and lowering pallets during loading or unloading without the use of mechanical springs, motors or hydraulics.
- The new EZ loader can now handle a wide range of weight capacities from 110 kilos to 1800 kilos.
- The EZ Adjust knob - a three position knob that allows adjustment of the collapsed capacity without changing the air pressure.
- EZ Loaders also allow easy pallet rotation for near-side loading so the worker does not have to reach or strain.
- As the load weight changes, the EZ Loader automatically adjusts, keeping the top of the load at a convenient working height.
- The patented pneumatic system found only on the EZ Loader has proven to be the choice of industry professionals worldwide.



View video of this in operation here,
www.mhaproducts.com.au/B1030



Code	Details	Load Capacity	Rotator Ring Dia.	Lifting Range	Base Frame Size	Unit Weight	WAS	NOW
B1030	EZ Loader	110-1800kg	1092mm	267-775mm	617x1245mm	220kg	\$5,783	\$5,089
EZ-ABS	Bellows Skirting to EZ Loader						\$1,679	\$1,490

Heavy Duty Manual Fork Stackers

- These manual fork stackers are constructed from very heavy duty materials, and are an economical alternative to forklifts.
- Manual hydraulic lift via pallet truck style handle or foot pedal.
- Straddle leg model for use with standard 1170mm Australian pallets.
- Standard leg model for use on Euro pallets and small skids.
- Lockable wheels are standard on all models.
- Load Capacity: 1000kg
- Rear Castors: 150mm
- Front Castors: 80mm



Code	Details	Lifting Range	Overall Size (LxWxH)	Unit Weight	WAS	NOW
S7256	Standard Leg Manual Fork Stacker	90-1600mm	1640x1000x2085mm	250kg	\$2,735	\$2,430
S7258	Straddle Leg Manual Fork Stacker	70-1600mm	1560x1450x2050mm	295kg	\$2,998	\$2,665

LIFTEX

Electric Platform Work Positioner

- A range of highly manoeuvrable, lightweight lifts, designed to take the strain out of any lifting job from ground level to over shoulder height
- Ideal for use in narrow aisles and confined spaces. Perfect for all applications from pharmaceutical to catering, from packing line to food processing
- Automatic electric overload protection system ensures safe operation
- Load Centre: 237mm
- Platform/ Attachment Size: 475x605mm
- Lifting/Lowering Speed: 55mm/s
- Steering Wheel: 100mm
- Battery: 12x2-10Ah
- Charger: DC-24V-2A
- Load Capacity: 100kg
- Lifting Range: 130-1700mm
- Overall Size (LxWxH): 920x505x2160mm
- Unit Weight: 65kg



LIFTEX

Code	WAS	NOW
M2190	\$3,065	\$2,725

4.5 Tonne Fixed Short Jib

This 4500kg short fixed jib is designed as an affordable general purpose jib which is great for confined spaces and has a 1.9 metre reach when fully extended.

- Finish: Zinc plated
- 4 jib positions
- Safe Working Load: 4500kg (SWL load chart is shown on jib)
- Jib Length (when closed): 1250mm
- Jib Length (when extended): 1900mm
- Fork Pocket Size: 185x65mm
- Fork Pocket Centres: 290mm
- Unit Weight: 95kg

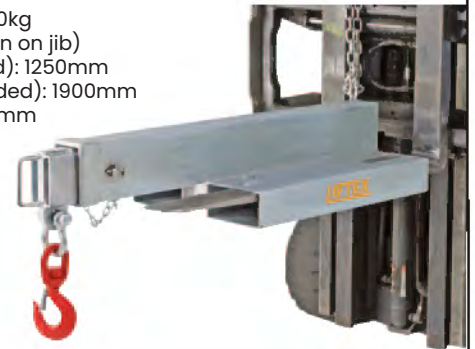

LIFTEX

Code	WAS	NOW
JS4500	\$1,350	\$1,192

SAFE WORKING LOADS (SWL) PER POSITION

POSITION	1	2	3	4
EXTENSION (mm)	670	1165	1545	1925
SWL (kg)	4500	2900	1300	750

4.5 Tonne Long Tilting Jib

This 4500kg long tilting jib is the most versatile jib in our range and allows for additional height of up to 2.23 metres.

- SWL chart is show in table
- Finish: Zinc plated
- 6 jib positions
- Overall Dimensions (closed): 2100x520x650mm (LxWxH)
- SWL: 4500kg
- Jib Length when Closed: 2100mm
- Jib Length when Extended: 3530mm
- Fork Pocket Size: 185x65mm
- Fork Pocket Centres: 322mm
- Unit Weight: 190kg

LIFTEX

SAFE WORKING LOADS (SWL) PER POSITION

POSITION	1	2	3	4	5	6
EXTENSION (mm)	770	2010	2390	2770	3150	3530
SWL (kg)	4500	1100	630	470	300	150

Code	WAS	NOW
TJ4500	\$2,460	\$2,180



Fork Extension Slippers / Tines (Galvanised)

- Fork slippers extend the versatility of your lift truck
- The safe working load (SWL) is measured per pair at 600mm load centre
- Slippers are manufactured in accordance to AS2359.15

Slippers should be no longer than 167% of the supporting tine length



Supplied with tine pins to secure slippers to forklift

LIFTEX

Code	SWL	Length	Internal Tine Size	External Tine Size	HCG	Weight per Pair	WAS	NOW
F2938	8000kg	1800mm	170x76mm	185x92mm	830mm	133kg	\$995	\$884
F2939	8000kg	2400mm	170x76mm	185x92mm	1135mm	177kg	\$1,235	\$1,095

Crane / Forklift Spreader Beam

The Spreader Beam is a unique multitasking Beam which can be used by Crane or Forklift to lift long loads. Using a Crane, loads can be lifted via the centre single hook point (as a 'Lifting Beam'), or end lifted using a 2 leg Chain Sling (as a 'Spreader Beam'). If lifting by forklift, the 600mm long slipper pockets allow for fast and safe connection to the truck.

The Spreader Beam load connection points are adjustable to 3 positions by moving the extendable arms each end. Both extendable arms are locked into position via safety pins. The unit is supplied standard with a safety swivel hook each end.

The extendable arms are zinc plated with the main body painted in 'safety orange'.

- F/Lift HCG: 300mm
- Fork Pocket Size: 190x65mm
- Fork Centres: 900mm
- Unit Weight: 172kg

Code	WAS	NOW
FL2439	\$2,540	\$2,257



LIFTEX

Rated Capacity When used as	Fully Retracted (LC @ 2405mm)	Middle Position (LC @ 2405mm)	Fully Extended (LC @ 3925 mm)
Forklift Attachment	3500kg	1500kg	750kg
Lifting Beam	4500kg	2500kg	1300kg
Spreader Beam	9000kg	7200kg	5600kg

Expanding Nylon Skate Conveyor

- Self tracking flexible conveyor which can expand from 1100mm to 4000mm
- Multiple units can be joined to make 1 continuous conveyor system
- Excellent for truck and container unloading and/or assembly lines
- Easy and quick setup with adjustable height legs and brake castors on every leg
- Reduces manual handling
- Bolted steel construction with nylon skate wheels
- Width: 610mm
- Load Capacity Per Metre: 75kg
- Castors: 105mm
- Length Retracted: 1100mm
- Length Expanded: 4000mm
- Height Range: 690-1000mm
- Unit Weight: 90kg



Nylon Skate Rollers

Code	WAS	NOW
40129N	\$1,985	\$1,765

Troden

Flexible Expanding Roller Conveyors (Expands 1.1 to 4.0m)

- The flexible expanding roller conveyor expands from 1500mm to 4000mm
- Multiple units can be joined to make 1 continuous conveyor system
- The roller conveyor is good for odd shaped cartons and bags of goods where the skate wheel conveyor wont work
- Easy and quick setup with height adjustable legs and 125mm brake castors on every leg
- Reduces manual handling
- Bolted steel construction with steel rollers
- Height Range: 690-1000mm
- Load Capacity Per Metre: 130kg
- Length Retracted: 1500mm
- Length Expanded: 4000mm



Steel Rollers



Code	Width	Unit Weight	WAS	NOW
40123	460mm	96kg	\$1,985	\$1,765
40124	610mm	116kg	\$2,095	\$1,863
40128	760mm	126kg	\$2,390	\$2,120

troden

Flexible Expanding Skate Conveyors (Expands 1.1 to 4.0m)

- Self tracking flexible expanding conveyor which expands from 1100mm to 4000mm
- Multiple units can be joined to make 1 continuous conveyor system
- Excellent for truck and container unloading and for assembly lines
- Easy and quick setup with adjustable height legs and brake castors on every leg
- Reduces manual handling
- Bolted steel construction with skate wheels
- Load Capacity Per Metre: 100kg
- Castors: 125mm
- Length Retracted: 1100mm
- Length Expanded: 4000mm
- Height Range: 690-1000mm



Code	Width	Unit Weight	WAS	NOW
40125	460mm	112kg	\$1,947	\$1,730
40129	610mm	124kg	\$2,090	\$1,858
40130	760mm	142kg	\$2,365	\$2,098

troden

Electric Expanding Roller Conveyors (Expands 1.5 to 4.0m)

- Simply plug in and go, this powered electric roller conveyor is great for carrying boxes and items up hill where gravity may not be achievable
- This conveyor is flexible and expands from 1500mm to 4000mm
- Multiple units can be joined to make 1 continuous powered conveyor system
- Great for loading and unloading containers
- Easy and quick setup with adjustable height legs and brake castors on every leg
- Quiet operation 240V AC motor with forward and reverse action and adjustable roller speed
- Load Capacity Per Metre: 140kg
- Castors: 125mm
- Length Retracted: 1500mm
- Length Expanded: 4000mm
- Height Range: 690-1000mm



Code	Width	Unit Weight	WAS	NOW
40143	460mm	126kg	\$6,320	\$5,620
40144	610mm	131kg	\$7,440	\$6,620
40145	760mm	172kg	\$7,685	\$6,835

troden

8 Tonne Capacity 1 Piece Container Ramp

- This container ramp is a great general purpose ramp for unloading containers using pallet trucks or forklifts.
- This is a one piece unit with forklift slots at the front for easy transport
- Finished in painted yellow and supplied with chain & D Shackle, the 8 Tonne container ramp is ready for immediate delivery.
- Load Capacity: 8000kg
- Width: 2200mm
- Height: 160mm
- Length: 1720mm
- Side Fork Pocket Size: 80x165mm
- Unit Weight: 240kg

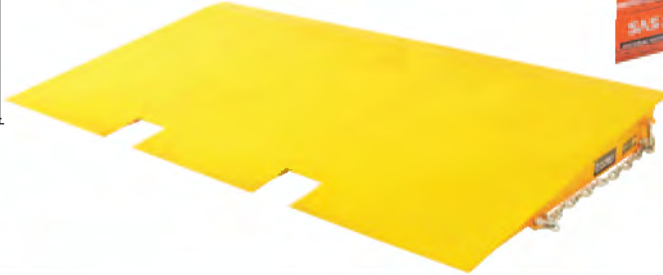
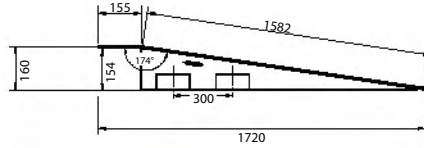
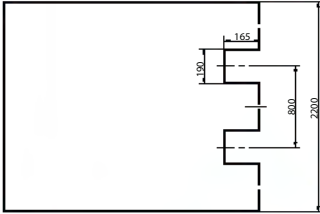

Code	WAS	NOW
R2996	\$1,490	\$1,320

troden

7 Tonne Capacity Container Ramp

This container ramp is designed primarily for bridging into a standard container from ground level that is slightly uneven due to its self-levelling lip. The ramp footing fold has handles which you can easily fold back to move the ramp using the fork slots.

- Capacity: 7000kg
- Unit Weight: 275kg
- Width: 2200mm
- Length: 2000mm
- Fork Pocket Size: 165x60mm
- Fork Pocket Centres: 775mm
- Supplied with chain and D-shackle as pictured
- Colour: Safety Yellow



Code	WAS	NOW
R2901	\$1,540	\$1,368

troden

Hydraulic Drum Truck

- Easily transport steel drums with this drum truck
- Pallet truck style design
- Nylon wheels
- Load Capacity: 365kg
- Min Arm Height: 270mm
- Max Arm Height: 390mm
- Radius of Arm: 270mm
- Overall Size (LxW): 1022x722mm
- Unit Weight: 53kg



LIFTEX

Code	WAS	NOW
DL7430	\$995	\$883

Powder Coated Drum Dolly

- Drum dollies are suitable for both steel and plastic drums and containers
- Powder coated finish
- Heavy duty easy wheel castors
- Load Capacity: 300kg
- Overall Size (LxWxH): 610x710x150mm
- Unit Weight: 7.5kg



Code	WAS	NOW
60415	\$94	\$84

LIFTEX

Side Shift Drum Palletiser

- The Side Shift Drum Palletiser is specially designed for moving drums and barrels from any position on a pallet.
- It uses a sliding side-shift arrangement allowing it to even be used for moving containers and drums placed in the centre of a pallet.
- The palletiser straddles the pallet and only requires access to one side, thus allowing pallets in confined areas to be kept against the wall even when unloading.
- When moving the drum onto another pallet, scales or the floor, the drum can also be moved to either side using the side-shift arrangement
- This unique design side shift drum palletiser can pickup drums from any position on the pallet, skid or bund -straddles beside and over the pallet
- Suitable for both steel and plastic drums
- The operator requires only 12kg of force on the handle to lift a 300kg drum
- Load Capacity: 350kg
- Ground/Pallet Clearance: 350mm
- Max Lift Height: 575mm
- Overall Size (LxWxH): 920x1550x1520mm
- Unit Weight: 168kg

View video of this in operation here,
www.mhaproducts.com.au/DL6974



LIFTEX

Code	WAS	NOW
DL6974	\$4,995	\$4,443

Drum Tipper/Dumper

- Fast and efficient solution to emptying 205 litre steel drums, ideally suited to waste and scrap products
- The drum is secured with the sturdy belly strap and locked in place with the over-centre catch and locking pin
- A rope draw chord is pulled from the driver's seat to dump the drum where required. A custom locking mechanism is fitted to prevent accidental release while driving over bumpy ground
- Working Load Limit (WLL): 500kg
- Rotational ability 180 degrees
- Load centre: 1000mm
- Fork pocket size 185 x 65mm
- Pocket centres 840mm
- Unit weight: 85kg



Code	WAS	NOW
DL7215	\$890	\$790

LIFTEX

Electric Drum Lifter & Rotator

These electric drum lifters pickup and rotate drums using battery electric power for both up and down and for tilting.

- Suitable for both steel and plastic drums
- Drum weighing scale version available online
- Lifting Speed: 120mm per second
- Rotation Speed: 180° - 30 seconds
- Capacity: 450kg
- Max Lift Height: 2300mm
- Distance Between Straddle Legs: 630mm
- Leg Length: 740mm
- Overall Height: 1600x950x1920mm (LxWxH)
- Battery: 12v, 120Ah
- Unit Weight: 355kg



Code	WAS	NOW
DL7206	\$8,017	\$7,130

LIFTEX

Lockable Storage Cages

- Heavy duty steel construction storage cages designed specifically for aerosol cans however are a great storage cage for tools and equipment.
- Power coated green
- All cages have lockable doors and bolt down plates for added security
- Designed to comply with relevant Australian Standards

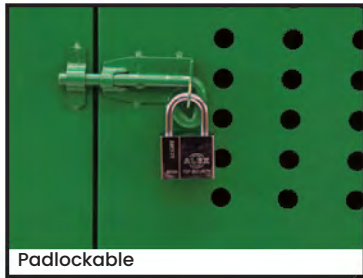

STORMAX

Code	Aerosol Can Storage Capacity	Internal Size (HxWxD)	External Size (HxWxD)	Distance between shelves	Unit Weight	WAS	NOW
AS8052	108	820x770x320mm	900x850x400mm	250mm	34kg	\$992	\$880
AS8055	432	1720x1575x320mm	1800x1655x400mm	325mm	131kg	\$2,103	\$1,869

Flammable Liquid Safety Cabinets

- High quality construction using zinc coated steel sheeting
- Powder coat finish giving high resistance to splashes and spills
- All products designed to comply with Australian Standards and relevant Dangerous Goods Regulations
- All cabinets supplied inclusive of all relevant safety signage and decals
- Adjustable slow release user friendly hydraulic door control closure systems
- Stainless steel continuous pin hinging for reliable and accurate door closing
- Adjustable and removable shelves



DG8100



DG8030



Code	Storage Capacity	Internal Size (HxWxD)	External Size (HxWxD)	Unit Weight	WAS	NOW
DG8030	30L	550x410x370mm	800x510x470mm	33kg	\$1,085	\$964
DG8100	100L	715x825x525mm	800x920x620mm	65kg	\$1,490	\$1,322

STORMAX

Forklift Gas Storage Cages

- Heavy duty steel construction storage cages specifically designed for storage of LPG cylinders used on forklifts
- Power coated green
- Cylinder chain restraint
- All cages have padlockable doors for increased safety
- Designed to comply with relevant Australian Standards



AS8042



AS8041

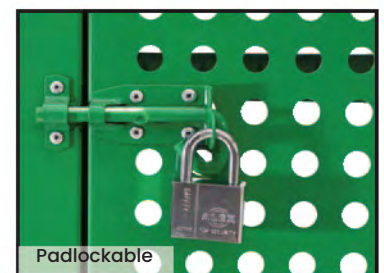

Padlockable

Code	LPG Cylinder Capacity	Internal Size (HxWxD)	External Size (HxWxD)	Unit Weight	WAS	NOW
AS8041	4	780x710x395mm	990x730x740mm	65kg	\$985	\$883
AS8042	6	840x1030x675mm	1005x1090x740mm	95kg	\$1,904	\$1,693

STORMAX

Foot Pedal Lid Lifting Wheelie Bins

- These wheelie bins come supplied with a foot pedal operated lid which avoids touching the lid when disposing of waste
- Manufactured from high density polyethylene
- Resistant to decay, heat, frost, chemicals and UV rays
- Bin Colour: Green (blue and grey also available)
- Ideal for food preparation areas
- Wheel Diameter: 200mm
- Bin Dimensions (WxDxH): 590x740x1070mm
- Capacity: 240L



Code	Details	WAS	NOW
WB240B	Wheelie Bin with foot pedal - Blue	\$295	\$259
WB240G	Wheelie Bin with foot pedal - Green	\$295	\$259
WB240GY	Wheelie Bin with foot pedal - Grey	\$295	\$259

WB240GY

WB240G

WB240B

VERDEX

70L Garbage Bins

- Small waste bins with four swivel castors
- Manufactured from high density polyethylene
- Resistant to decay, heat, frost, chemicals and UV Rays
- Castors: 50mm
- Bin Capacity: 70L
- Overall Size: 450x440x680mm
- Unit Weight: 5kg



Code	Details	WAS	NOW
WB70GY	70L Garbage Bin - Grey	\$98	\$85
WB70G	70L Garbage Bin - Green	\$98	\$85

WB70GY

WB70G

VERDEX

Self Dumping 1500kg Capacity Tipping Bins (Hot Dipped Galvanised)

- These large self dumping tipping bins are suitable for any waste and rubbish application
- Heavy duty construction with self dumping ability, the forklift empties the bin without the operator leaving the drivers seat
- Supplied with 4 crane lugs (top) and 2 upending lugs (underneath)
- Available in 3 standard sizes
- Optional wheel kit available
- Hot dipped galvanised finish

View video of this in operation here,
www.mhaproducts.com.au/WB2920



WB2922

troden



WB2920



WB2921



Optional Wheel Kit Available



Code	Bin Capacity	Fork Pocket Centres	Overall Size (WxLxH)	Unit Weight	WAS	NOW
WB2920	950L	380mm	1150x1570x1010mm	180kg	\$1,650	\$1,462
WB2921	1250L	680mm	1310x1570x1010mm	205kg	\$1,830	\$1,620
WB2922	1850L	680mm	1910x1570x1010mm	245kg	\$2,470	\$2,190
WB29K	Wheel Kit to suit Tipping Bins (includes 4 wheels)				\$305	\$269

Drop Bottom Bin (Solid Sides)

- These drop bottom bins are a heavy duty bin made for all types of waste
- This bin is able to be transported either by forklifts or cranes
- Emptying is carried out by pulling the draw rope handle which allows the floor to drop open from one side allowing complete emptying
- Sheet metal sides with sheet metal base
- Durable Zinc finish
- Volume: 1500L
- SWL: 1000kg
- Bin Dimensions (LxWxH): 1540x950x1350mm
- Fork Pocket Size: 160x65mm
- Fork Pocket Centres: 784mm
- Unit Weight: 200kg



Code	WAS	NOW
WB2722	\$1,850	\$1,642

troden

Drop Bottom Bin (Mesh Sides)

- These drop bottom bins are a heavy duty bin made for all types of waste
- Ideally suited to the recycling industry, the cage can be lifted by either a forklift or crane
- This bin is able to be transported either by fork lifts or cranes
- Emptying is carried out by pulling the draw rope handle which allows the floor to drop open from one side allowing complete emptying
- Mesh sides with sheet metal base
- Volume: 1500L
- SWL: 1000kg
- Bin Dimensions (LxWxH): 1540x950x1350mm
- Fork Pocket Size: 160x65mm
- Fork Pocket Size: 784mm
- Unit Weight: 145kg



Code	WAS	NOW
WB2723	\$1,560	\$1,385

troden



Parts Bin Trolleys

- PVC mat on top and bottom tray
- Transparent front window on the parts bin
- Each bin comes with one divider and one bin label card
- Parts trays have a raised back lip
- Plastic Parts Bin size (LxWxH): 450x165x105mm
- 265mm distance between bottom and middle shelf on C7226 model
- 400kg load capacity
- Rubber castors - 2 x fixed, 2 x swivel with brakes
- Castors: 100mm
- Distance between Shelves: 110mm
- Shelf Size: 755x465mm



tanko

Code	Details	Unit Weight	WAS	NOW
C7226	Parts Bin Trolley (8 parts bins)	34kg	\$572	\$505
C7227	Parts Bin Trolley (16 parts bins)	38kg	\$739	\$650

Mobile Panel Cart with Storage Cabinet

- The Panel Cart is used for transporting and storing a range of products
- Three storage shelves plus the base mean that numerous products of larger size can be stored neatly, but can still be easily accessed.
- Pegboard Size (WxH): 850x300mm
- Louvre and pegboard panels are compatible with our Stor-Pak and pegboard accessories
- Storage cabinet supplied with a lock
- Powder coated dark grey finish
- Rubber castors - 2 x swivel, 2 x swivel with brakes
- Castors: 125mm
- Shelf Capacity: 50kg
- Shelf Size: 870x150mm
- Cupboard Internal Size (WxDxH): 865x220x430mm
- Overall Size (LxWxH): 1025x670x1420mm
- Unit Weight: 63kg



VERDEX

Code	WAS	NOW
M7275	\$710	\$572

Access Plastic Bin Rack

- These access bin racks store and display products for easy access and stock picking
- Extra strong powder coated frames and beams
- Rack fits the No. 4D size bins (choice of 6 colours)
- Includes 28 bins
- Storage Bin Size (LxWxD): 430x323x210mm
- This rack can have castors fitted for easy maneuverability
- Width: 2400mm
- Height: 1800mm
- Depth: 450mm



Bin Colours Available:
(Please specify your preferred bin colour when placing your order)



STORMAX

Code	Description	WAS	NOW
10425	Access Bin Rack - Initial Bay	\$988	\$877
10425A	Access Bin Rack - Add on Bay	\$925	\$820

Access Stor-Pak Bin Rack

- These access Stor-Pak bin racks store and display products for easy access and stock picking
- Extra strong powder coated frames and beams
- Rack fits the IH-065 Stor-Pak #240 bins (choice of 4 colours)
- Includes 20 bins
- Stor Pak Bin Size (LxDxH): 410x440x210mm
- This rack can have castors fitted for easy maneuverability
- Width: 2400mm
- Height: 1800mm
- Depth: 450mm



Bin Colours Available:
(Please specify your preferred bin colour when placing your order)



STORMAX

Code	Description	WAS	NOW
10427	Access Bin Rack - Initial Bay	\$1,246	\$1,105
10427A	Access Bin Rack - Add on Bay	\$1,174	\$1,043

Heavy Duty Steel and Mesh Longspan Shelving

- This heavy duty longspan shelving system is a strong and versatile shelving system, which is similar to pallet racking just in a smaller profile, which is great for storing small parts and archives.
- This system is supplied standard with 3 adjustable shelves however extra shelf levels can be ordered for each set
- End frames are supplied assembled for quick and easy setup
- Step beams so that the shelves sit flush inside the beam
- Shelf Capacity: 375kg per shelf (evenly distributed)
- Steel and Mesh shelves are supplied as 2 separate pieces per level
- Step beams which the mesh decks sit flush with the beam
- For overall bay length add 60mm per frame

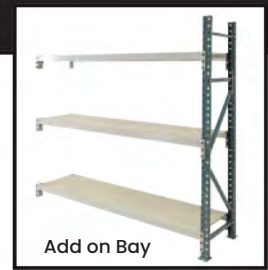

2400mm Wide Longspan (with 3 steel shelf levels)						
Code	Details	Height (mm)	Width (mm)	Depth (mm)	WAS	NOW
LS2402S	Initial Bay	2400	2400	450	\$734	\$650
LS2402SA	Add-On Bay	2400	2400	450	\$640	\$567
Extra Shelf Codes						
LS2400SE	Extra Shelf Set	2400x450mm (WxD)			\$182	\$160



See online for more sizes and configurations



2400mm Wide Longspan (with 3 mesh shelf levels)						
Code	Details	Height (mm)	Width (mm)	Depth (mm)	WAS	NOW
LS2402M	Initial Bay	2400	2400	450	\$751	\$667
LS2402MA	Add-On Bay	2400	2400	450	\$657	\$580
Extra Shelf Codes						
LS2400ME	Extra Shelf Set	2400x450mm (WxD)			\$188	\$165



Stack & Nest Crate Dolly

- Zinc plated wheels with bearings
- Stackable for secure storage through reservoirs for the wheels
- Dimensions (LxWxH): 405x610x170mm
- Internal Base Dimensions: 545x390mm
- Load Capacity: 250kg
- Unit Weight: 4.5kg



Code	WAS	NOW
13098	\$125	\$108

Steel Corner Protector

- Great for protecting corners of garages or expensive equipment in warehouses or factories
- Made from powder coated steel
- Colour: Yellow
- Overall Size (LxWxH): 1800x200x200mm



Code	WAS	NOW
AB7849-1	\$120	\$99

Wire Pallet Cages

Convert your pallets into cages with the quick and easy to use cages.

- Ideal for storing odd or awkward shaped goods/products
- Can be folded down flat for easy storage when not in use
- Pallet not included
- Mesh Size: 100x50x6mm
- SC753 Overall Size (WxDxH): 1195x1170x400mm
- SC754 Overall Size (WxDxH): 1195x1170x800mm



STORMAX

Code	Details	Unit Weight	WAS	NOW
SC753	1/2 Height Pallet Cage	28kg	\$245	\$215
SC754	Full Height Pallet Cage	44kg	\$320	\$280

SC753 - 1/2 Height

SC754 - Full Height

Galvanised Mesh Cage

These mesh cages are an excellent form of warehouse and yard storage.

These units are stackable as well as having the capability of being stored in a pallet rack.

- Can be folded down flat for easy storage when not in use
- Folded Height: 300mm
- Can be safely stacked 4 high when in use and when empty
- Load Capacity: 1000kg
- Folded Height: 300mm
- Mesh Size: 100x50x6mm
- Overall Size (WxDxH): 1150x1150x890mm
- Unit Weight: 80kg



Code	WAS	NOW
SC750	\$435	\$385

STORMAX

Low Galvanised Storage Cage

This Galvanised Storage Cage is great for storing products both indoor and outdoor.

- Pallet Rack Safe – Unique Positive Locking Base Design
- These cages can also be stored on pallet racking
- Drop down removable front gate
- Cages can be stacked 2 high when loaded
- 4 Way forklift & 2 Way Pallet Truck entry
- Finish: Zinc plated
- Supplied flatpacked
- Load Capacity: 1000kg
- Base Height: 125mm
- Internal Size (LxWxH): 1070x1070x480mm
- Overall Size (LxWxH): 1160x1205x652mm
- Unit Weight: 61kg



Code	WAS	NOW
SC377	\$578	\$512

STORMAX

Stackable Mesh Stillage Picking Cage

- Can be double stacked
- Drop down/removable gates
- Supplied flatpacked for easy transport
- Finish: Blue powder coated
- Base Height: 400mm
- Overall Size: 1165x1165x1650mm
- Load Capacity: 750kg
- Unit Weight: 96kg



STORMAX

Code	WAS	NOW
SC880C	\$905	\$796

Collapsible & Stackable Stillage Cage

Multi-purpose transport or storage cages which are great for storing products both indoor and outdoor.

- Pallet Rack Safe – Unique Positive Locking Base Design
- These cages can also be stored on pallet racking
- Fold down gates
- Front and rear gates are removable and half
- Quick collapse sides so the unit can be quickly folded, stored and transported in the knock-down position
- Cages can be stacked 3 high when loaded and 10 high folded
- Finish: Zinc plated
- Supplied flatpacked
- Load Capacity: 1200kg
- Internal Size (LxWxH): 1035x1035x805mm
- Overall Size (LxWxH): 1125x1125x1040mm
- 4 way pallet truck and forlift entry
- Unit Weight: 80kg



Code	WAS	NOW
M7541	\$720	\$639

STORMAX

Stackable Stillage Cage

Designed to store long awkward objects for easy transport, these units may be stacked to make use of the vertical space in your warehouse.

- Fits standard Australian size pallets including Chep and Loscam
- Can be safely stacked 3 high when in use and 5 high when empty
- Finish: Zinc plated
- Base Material Size: RHS 30x60x1.8mm
- Post Size: 60x2.5mm
- Cupped feet add an additional 100mm to the external size (50mm per side)
- Clearance between ground and bottom frame is 110mm
- Clearance between stillages when stacked is 1545mm
- Load Capacity: 1000kg
- Post Height from Top of Base: 1490mm
- Internal Size (LxWxH): 1250x1250x1490mm
- External Size (LxWxH): 1390x1390x1655mm
- Base Height: 170mm
- Unit Weight: 54kg

STORMAX

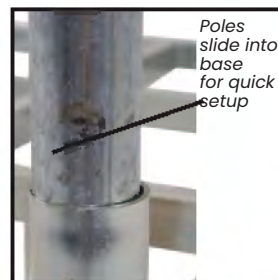

Code	WAS	NOW
SC955	\$424	\$375



Heavy Duty Industrial Workbenches

- Heavy duty steel industrial workbench with bottom shelf is ideal for use as a work or tool bench
- 1000kg wood top bench capacity
- 53mm thick laminated wooden top
- Comes standard with adjustable feet for levelling on uneven floors and an optional lockable castor kit is available if required
- Drawer Unit Capacity: 100kg per drawer
- Finish: Powder coated light grey

STORMAX



Workbench with bottom shelf
M7305: 1200mm long
M7306: 1800mm long
M7307: 2100mm long



Image shown with,
M7307: Industrial Work Bench (with bottom shelf)
B8108: Back Panel



B8100 - 2 Drawer Unit
 2 x 100mm drawers

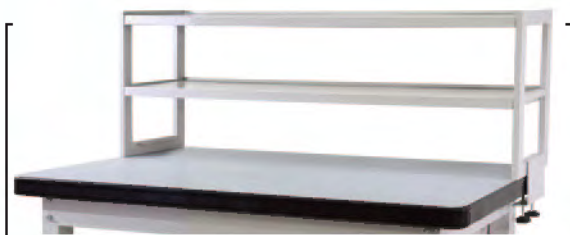

M7253 - 2 Tier Shelf Unit to suit 1200mm Workbenches
M7254 - 2 Tier Shelf Unit to suit 1800mm Workbenches
M7255 - 2 Tier Shelf Unit to suit 2100mm Workbenches



M7312 - Lockable Drawer Unit to suit
 M7305, M7306 and M7307 Workbenches



M7315 - Lockable Cabinet Unit to suit
 M7305, M7306 and M7307 Workbenches

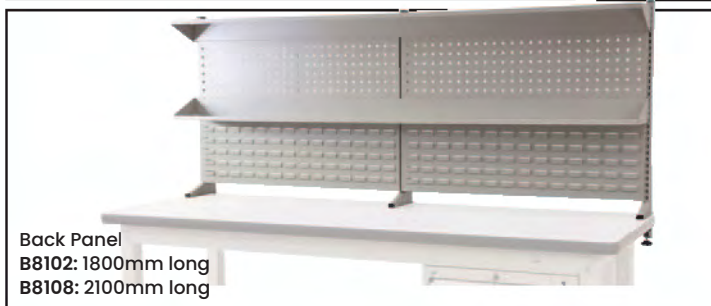

Back Panel
B8102: 1800mm long
B8108: 2100mm long

M7250 - Adjustable Shelf to suit 1200mm Workbenches
M7251 - Adjustable Shelf to suit 1800mm Workbenches
M7252 - Adjustable Shelf to suit 2100mm Workbenches

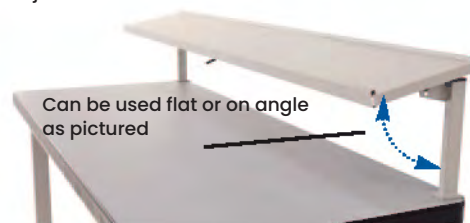

Can be used flat or on angle
 as pictured

Code	Details	Dimensions (mm)	WAS	NOW
M7305	Industrial Workbench 1200mm (with bottom shelf)	1200x750x800 (WxLxH)	\$593	\$525
M7306	Industrial Workbench 1800mm (with bottom shelf)	1800x750x900 (LxWxH)	\$845	\$750
M7307	Industrial Workbench 2100mm (with bottom shelf)	2100x750x900 (LxWxH)	\$873	\$775
M7312	Lockable Drawer Unit to suit M7305, M7306 and M7307 Workbenches	565x650x450 (WxDxH)	\$656	\$580
M7315	Lockable Cabinet Unit to suit M7305, M7306 and M7307 Workbenches	565x650x450 (WxDxH)	\$320	\$283
M7250	Adjustable Shelf Unit to suit 1200mm Workbench	1200x250mm (LxD)	\$104	\$91
M7251	Adjustable Shelf Unit to suit 1800mm Workbench	1800x250 (LxD)	\$125	\$109
M7252	Adjustable Shelf Unit to suit 2100mm Workbench	2100x250 (LxD)	\$137	\$119
M7253	2 Tier Shelf Unit to suit 1200mm Workbench	1200x285 (LxD)	\$160	\$139
M7254	2 Tier Shelf Unit to suit 1800mm Workbench	1800x285 (LxD)	\$197	\$175
M7255	2 Tier Shelf Unit to suit 2100mm Workbench	2100x285 (LxD)	\$216	\$190
B8100	Workbench 2 Drawer Unit	565x580x280 (WxDxH)	\$294	\$260
B8102	Back Panel to suit 1800mm Workbench	1735x205x825 (LxWxH)	\$325	\$289
B8108	Back Panel to suit 2100mm Workbench	2035x205x825 (LxWxH)	\$348	\$307

Heavy Duty Industrial Workbench - 900 Series

- Heavy duty steel industrial workbench is ideal for use as a work or tool bench
- This workbench has a 600kg top bench capacity
- 28mm thick laminated wooden top
- Comes standard with adjustable feet for levelling on uneven floors
- Finish: Powder coated light grey
- M7300 Overall Size (WxDxH): 900x750x800mm
- M7310 Overall Size (WxDxH): 410x680x180mm
- M7310 Drawer Depth: 100mm



M7300 pictured with M7310

STORMAX

Code	Details	WAS	NOW
M7300	Industrial Workbench	\$365	\$320
M7310	Lockable Drawer Unit to suit M7300	\$247	\$217

Industrial Tooling Workstation

- Heavy duty tooling cabinets for industrial workshop applications
- The sliding drawers have quality smooth operation bearings
- Lockable cupboard with adjustable shelf
- Finish: Powder coated light grey and blue
- 2 fixed castors and 2 swivel lockable castors
- Fixed metal pegboard panel which suits our range of hooks and accessories
- Rubber mat on workbench area
- 5 lockable drawers with dividers (3 x 100mm and 2 x 200mm drawers)
- Individual Drawer Capacity: 75kg
- Bench Height: 950mm
- Overall Size (LxWxH): 1100x580x1450mm
- Unit Weight: 115kg



STORMAX

Code	WAS	NOW
C8185	\$1,495	\$1,330

Industrial Cabinet with 2 Drawers

- Storage cabinet is ideal for workshop and industrial applications
- Pegboard, drawer and cupboard storage spaces guarantee various sized tools and equipment can be stored efficiently
- Metal pegboard to neatly arrange tools and equipment for easy access
- Can be used without Pegboard
- Sliding drawers with adjustable dividers.
- 2 door lockable cabinet with 1 adjustable shelf
- Shelf Capacity: 100kg
- Drawer Capacity: 75kg
- Bench Height: 1010mm
- Bench Size: 875x555mm
- Pegboard Size: 870x500mm
- Overall Size (LxWxH): 900x585x1515mm
- Unit Weight: 90kg



STORMAX

Code	WAS	NOW
M7211	\$1,359	\$1,205

7 Drawer Industrial Tooling Cabinet

- Heavy duty tooling cabinets, ideal for heavy duty industrial applications
- The sliding drawers are a welded strengthened single rail design coupled with high quality mechanical bearings for long lasting smooth operation
- Single key lock design for safe storage.
- All drawers come with adjustable steel dividers
- Drawer 1 to 6: 150mm high
- Drawer 7: 200mm high
- Individual Drawer Capacity: 100kg
- Overall Unit Capacity: 600kg
- Overall Size (WxDxH): 881x653x1200mm
- Unit Weight: 135kg



STORMAX

Code	WAS	NOW
C8125	\$1,420	\$1,265

6 Drawer Unit with optional Castor Kit

- Ideal for industrial applications and serious workshops
- The sliding drawers are a welded strengthened single rail design featured with high quality mechanical bearings for long lasting smooth operation
- Single key lock design for safe storage. Each drawer has a mechanical safety lock which allows one drawer to be opened at a time, preventing the cabinet from tipping over
- Drawer Capacity: 100kg
- 6 Drawers: 2 x 75mm, 2 x 150mm, 2 x 200mm drawers
- B8103 Overall Size: 565x580x750mm (WxDxH)
- Overall Height with C8103 (Wheel and Handrail Kit): 900mm
- Powdercoated light grey/blue finish



B8103 pictured with C8103 castor kit and handrail



Code	Details	WAS	NOW
B8103	6 Drawer Unit	\$985	\$854
C8103	Optional Wheel and Handrail Kit	\$156	\$138

STORMAX

30L Wet & Dry Vacuum Cleaner

- Industrial Wet and Dry Vacuum Cleaner
- Portable on wheel base with push handle
- Complete with all accessories
- Suitable for large workshops and factories
- Fitted with standard 10Amp 240V plug
- 1200W motor
- 53L/second
- Hose Length: 2500mm
- Cable Length: 7200mm
- Height of Machine: 720mm



VERDEX

Code	WAS	NOW
M3000	\$375	\$332

40L Manual Floor Sweeping Machine

- Ideal for sweeping factory floors, carparks, footpaths, entry ways etc
- Independant rolling brushes prevent waste fallback
- Sweeper works by simply being pushed along which activates the roller and brushes
- Waste is picked up by the roller and brushes and pushed into the waste container located under the main cover
- Waste container is removable allowing for easy tipping into another bin
- Waste container capacity - 40 Litres
- Overall Size (LxWxH): 1260x960x1040mm
- Cleaning Width: 920mm
- Unit Weight: 23kg



VERDEX

Code	WAS	NOW
WS9000	\$838	\$744

Heavy Duty 30 Parts Tray Cabinet

- These Heavy Duty Parts Cabinets are a great way to store parts neatly and efficiently
- Parts Trays have a transparent front window to easily view product inside
- Parts trays have a raised back lip
- Each bin comes with one divider and one bin label card
- Different color tags can be applied for easier identification
- Parts Bin Capacity: 10kg each
- Plastic Parts Bin Size (LxWxH): 415x170x105mm
- Overall Size (WxDxH): 900x420x880mm
- Unit Weight: 51kg



tanko

Code	WAS	NOW
C7350	\$835	\$742

Heavy Duty 60 Parts Tray Cabinet

- These Heavy Duty Parts Cabinets are a great way to store parts neatly and efficiently
- Parts Trays have a transparent front window to easily view product inside.
- Parts trays have a raised back lip
- Each bin comes with one divider and one bin label card
- Different color tags can be applied for easier identification
- Parts Bin Capacity: 10kg
- Plastic Parts Bin Size (LxWxH): 415x170x105mm
- Overall Size (LxWxH): 900x420x1760mm
- Unit Weight: 110kg



tanko

Code	WAS	NOW
C7351	\$1,482	\$1,315

Louvre & Pegboard Panel Trolleys

- Strong metal panel trolleys which are ideal for storing either Stor-Pak Bins or tools on hooks
- Fitted with 4 swivel castors (2 with brakes)
- Powder coated grey colour
- Can be ordered one side with louvre panel and one side with square hole metal pegboard with code 10736
- Wheels can be removed to make fixed shelving if required
- Stor-Pak Bins and panel hooks are sold separately
- Overall Size (LxWxH): 980x600x1540mm
- Unit Weight: 60kg
- 10730K Unit Weight: 85kg

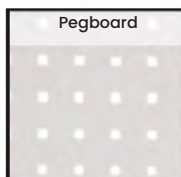
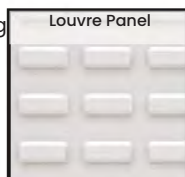

Code	Details	WAS	NOW
10730	Louvre Panel Trolley	\$675	\$599
10735	Square Pegboard Panel Trolley	\$675	\$599
10736	Panel Trolley (1 side pegboard & 1 side louvre panel)	\$675	\$599
10730K	Louvre Panel Trolley Kit (with Stor-pak bins as pictured)	\$1,085	\$965

STORMAX

7.1 Metre Expanding Barrier

- Made from powder coated steel and aluminium
- Colour: Black
- Rubber castors - 8 x swivel with brakes
- Castors: 75mm
- Base Width: 460mm
- Collapsed Size (LxH): 560x2050mm
- Expanded Size (LxH): 7100x1930mm
- Barrier Tube Size: 20x20mm
- Post Size: 40x40mm
- Unit Weight: 36kg

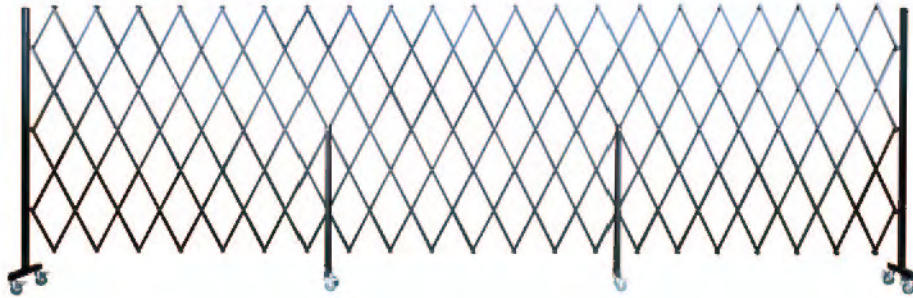

Code	WAS	NOW
M7415	\$1,125	\$997

STORMAX

3 Metre Expanding Barrier

- Made from powder coated steel, aluminium and high-tech plastics
- Colour: Black/Yellow
- Compact design, weighs only 6kgs
- Expanded Length: 3 metres
- Rubber Castors- 4 x swivel with brakes
- Castors: 50mm
- Collapsed Dimensions: 350x1030mm
- Expanded Size (LxH): 3000x1030mm
- Height with castors: 1030mm
- Height without castors: 970mm
- Unit Weight: 6kg

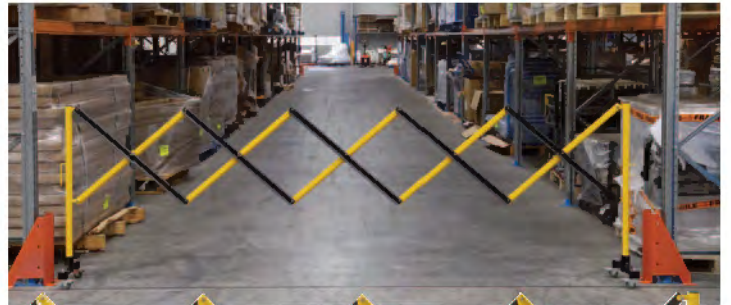

STORMAX

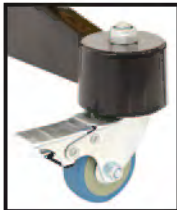

Code	WAS	NOW
M7412	\$255	\$225

Pallet Racking Column Guard

- Pallet Racking Column Guards are a highly effective solution for preventing damage to racking and inventory by forklifts.
- You can avoid major injuries and pallet rack damage by installing these protection guards.
- Conforms to relevant Australian Standards
- Overall Size (HxD): 400x220mm

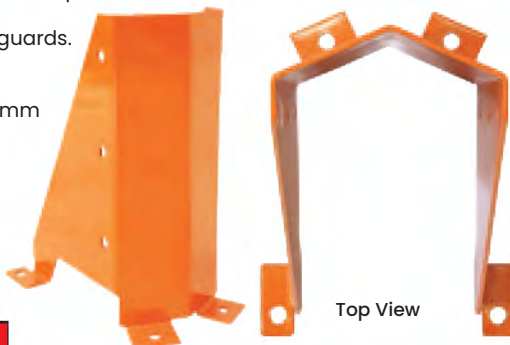

Top View

STORMAX

Code	WAS	NOW
11327	\$67.20	\$58

Galvanised Safety Bollard

- Ideal for protecting expensive equipment and racking from possible forklift damage
- Great for protecting edges of roller doors from truck damage
- Bollard Height: 1200mm
- Bollard Diameter: 165mm
- Wall Thickness: 3mm
- Base Plate Size: 280x280mm
- Base Plate Thickness: 10mm
- Bolt Hole Size: 17mm
- M16 Tru Bolts available to suit



AB8706



STORMAX

Code	Details	WAS	NOW
AB8705	Galvanised Bollard	\$182	\$160
AB8706	M16 Tru Bolt	\$3.50	\$2.50

Safety Guard Rail Barrier Fencing

- Protect expensive equipment from forklift damage using bolt together post and panel modular system
- Heavy duty powdercoat yellow steel construction
- Easily assembled and disassembled rail system
- Supplied with all necessary bolts and fixings
- Base Size of the post is 255x255x16mm



Corner Post Comes with bolt holes on two adjoining sides

Centre Post Comes with bolt holes on two opposite sides

Base Size of the post is 255x255x16mm



SG405 - 1120mm long



SG406 - 1730mm long



SG407 - 2340mm long



SG408 - 2945mm long



SG402

SG404



SG403

SG401



Single Rail



Double Rail



Code	Description	Height (mm)	Dimensions (mm)	WAS	NOW
SG401	Single Height Corner/End Post	470	100x100	\$198	\$175
SG402	Single Height Centre Post	470	100x100	\$198	\$175
SG403	Double Height Corner/End Post	1085	100x100	\$234	\$207
SG404	Double Height Centre Post	1085	100x100	\$234	\$207
SG405	Safety Rail Section - 1120mm long	370	-	\$198	\$175
SG406	Safety Rail Section - 1730mm long	370	-	\$222	\$198
SG407	Safety Rail Section - 2340mm long	370	-	\$346	\$307
SG408	Safety Rail Section - 2945mm long	370	-	\$348	\$307



Fixed Safety Bollards

- Ideal for protecting expensive equipment and racking from possible forklift damage
- Great for protecting edges of roller doors from truck damage
- Finish: Powdercoated yellow
- Bolt Hole Size: 22mm
- Bollard Diameter: 115mm
- M16 Tru Bolts available to suit
- Wall thickness: 3mm

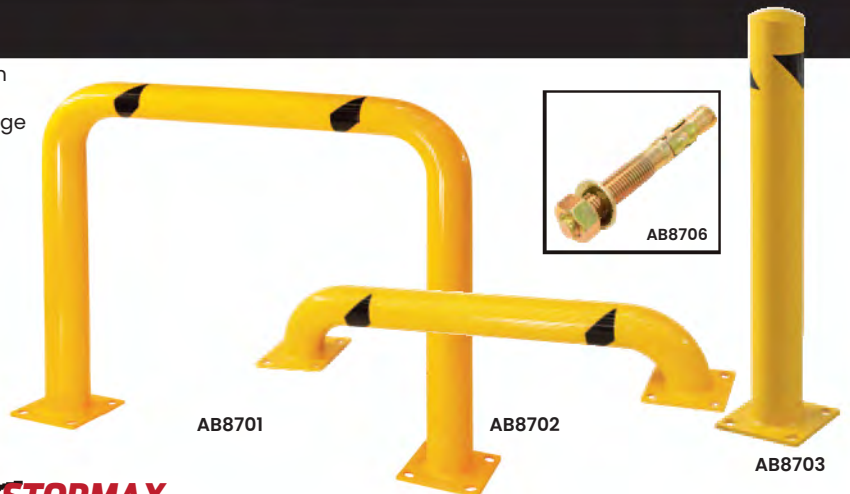

AB8706

AB8701

AB8702

AB8703



Code	Dimensions (mm)	WAS	NOW
AB8701	1068x1220x115 (HxWxD)	\$379	\$335
AB8702	230x1220x115 (HxWxD)	\$210	\$185
AB8703	915x115(HxD)	\$119	\$105
AB8706	M16 Tru Bolt	\$3.50	\$2.50

Large Powered Platform Trolley



T9308

NOW \$4,750
SAVE \$590

Stillage Mesh Cage



SC940

NOW \$697
SAVE \$93

X-Cart Folding Trolley



T9000

NOW \$249
SAVE \$146

Stainless Steel Platform Trolley



ST615

NOW \$693
SAVE \$87

Liftex 1000kg Tow Tug



ST1000

NOW \$6,260
SAVE \$780

Parrot Beak Drum Lifter



DL2940

NOW \$777
SAVE \$98

Peg board Tool Trolley



T8186

NOW \$421
SAVE \$54

5 Tonne Heavy Duty Pallet Truck



PT7205

NOW \$1,890
SAVE \$235

Roll Prong



F2992

NOW \$1,423
SAVE \$177

TAX TIME SAVINGS

On sale until June 30th 2022



© MHA Products 2022
ABN 38 368 064 476
Head Office Postal Address:
PO Box 2157,
North Parramatta NSW 1750

Sydney (02) 8865 1800
nsw@mhaproducts.com.au

Melbourne (03) 9115 9100
vic@mhaproducts.com.au

Brisbane (07) 3558 9700
qld@mhaproducts.com.au

MHA
PRODUCTS
MATERIALS HANDLING & STORAGE EQUIPMENT

View more
of our special
offers online

Visit our website

mhaproducts.com.au