

MHA

Workplace & Office Equipment



MHA
PRODUCTS

 1800 750 900

Office Furniture

Colour Options (please specify when placing your order)

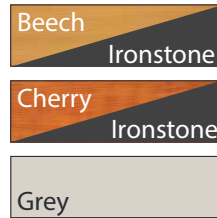

- Quality office furniture supplied flat pack ready for quick and easy installation
- We can arrange installation if required
- A choice of 3 colours as pictured to the right is available in most pieces of furniture (please specify colour choice when placing your order)
- 3 year warranty

Workplace & Office Equipment



Straight Office Desk

Code	Description	Dimensions (LxW)	Price Each	
			1-9	10+
FS4001	Straight Office Desk	1800x900mm	\$270.00	\$POA
FS4002	Straight Office Desk	1500x750mm	\$250.00	\$POA
FS4003	Straight Office Desk	1800x750mm	\$220.00	\$POA
FS4004	Straight Office Desk	1200x600mm	\$166.00	\$POA
FS4005	Straight Office Desk	900x600mm	\$138.00	\$POA

3 Piece Corner Workstation



Code	Description	Dimensions (LxWxD)	Price Each	
			1-9	10+
FS4006	CNR Workstation	1200x1200x600mm	\$382.00	\$POA
FS4007	CNR Workstation	1200x1500x600mm	\$394.00	\$POA
FS4008	CNR Workstation	1200x1800x600mm	\$402.00	\$POA
FS4009	CNR Workstation	1200x2100x600mm	\$428.00	\$POA
FS4010	CNR Workstation	1500x1500x600mm	\$402.00	\$POA
FS4111	CNR Workstation	1800x1500x600mm	\$410.00	\$POA
FS4112	CNR Workstation	1800x1800x600mm	\$418.00	\$POA
FS4113	CNR Workstation	2100x1500x600mm	\$436.00	\$POA
FS4114	CNR Workstation	2100x1800x600mm	\$444.00	\$POA
FS4115	CNR Workstation	2100x2100x600mm	\$470.00	\$POA



Image shown is right hand side version

1 Piece Corner Workstation

Code	Description	Dimensions (LxW)	Price Each	
			1-9	10+
FS4011	Corner Desk -Left	1800x1200x900mm	\$386.00	\$POA
FS4012	Corner Desk -Right	1800x1200x900mm	\$386.00	\$POA



Desk Return

Code	Description	Dimensions (LxW)	Price Each	
			1-9	10+
FS4013	Desk Return	900x450mm	\$142.00	\$POA
FS4014	Desk Return	900x600mm	\$166.00	\$POA
FS4015	Desk Return	1200x600mm	\$178.00	\$POA

Drawer Units

Code	Description	Price Each	
		1-9	10+
FS4016	Fixed Drawer Unit - 1 Drawer	\$58.00	\$POA
FS4017	Fixed Drawer Unit with 1 Filing Drawer	\$140.00	\$POA



FS4017 unit is lockable



Desk Hob

Code	Description	Dimensions (LxDxH)	Price Each	
			1-9	10+
FS4019	Desk Hob	1500x350x400mm	\$118.00	\$POA
FS4020	Desk Hob	1800x350x400mm	\$140.00	\$POA

Desk Hob is not available in grey

Mobile Pedestals



Lockable Drawers

Code	Description	Dimensions (WxDxH)	Price Each	
			1-9	10+
FS4021	Mobile Pedestal - 2 File Drawers	690x465x447mm	\$230.00	\$POA
FS4022	Mobile Pedestal - 3 Drawer (2 box drawer, 1 file drawer)	690x465x447mm	\$230.00	\$POA
FS4023	Mobile Pedestal - 4 Drawer (4 box drawers)	690x465x447mm	\$230.00	\$POA



Code: FS4025
Image shown is the left version

Conference Desk End

Code	Description	Dimensions (WxDxH)	Price Each	
			1-9	10+
FS4024	Conference Desk End -Right	2300x900x1050mm	\$406.00	\$POA
FS4025	Conference Desk End -Left	2300x900x1050mm	\$406.00	\$POA

Pigeon Hole Unit

Code	Description	Price Each	
		1-5	6+
FS4026	Pigeon Hole Unit	\$474.00	\$POA

Pigeon Hole Unit is not available in grey

Code: FS4026
Size: 1040x1040x380mm (HxWxD)
Adjustable Shelves
20 Holes



Bookcase Unit

Bookcase
Adjustable 25mm Shelves



Code	Description	Dimensions (HxWxD)	Price Each	
			1-9	10+
FS4027	Bookcase	900x900x315mm	\$200.00	\$POA
FS4028	Bookcase	1200x900x315mm	\$224.00	\$POA
FS4029	Bookcase	1800x900x315mm	\$270.00	\$POA

Code: FS4030
Size: 1800x900x450mm (HxWxD)
Includes 3 shelves

Code: FS4031
Size: 1800x900x450mm (HxWxD)
3 Adjustable Shelves



Lockable Cupboard & Wall Unit

Code	Description	Price Each	
		1-9	10+
FS4030	Lockable Cupboard	\$460.00	\$POA
FS4031	Lockable Wall Unit	\$274.00	\$POA
FS4030S	*Extra Shelves to suit FS4030	\$48.00	\$POA

**not available in grey*



Hutch Unit

Code	Description	Dimensions (WxHxD)	Price Each	
			1-9	10+
FS4032	Hutch	1200x1070x315mm	\$274.00	\$POA
FS4033	Hutch	1500x1070x315mm	\$310.00	\$POA
FS4034	Hutch	1800x1070x315mm	\$354.00	\$POA

Filing Cabinet

Code	Description	Dimensions (HxWxD)	Price Each	
			1-9	10+
FS4035	Filing Cabinet - 3 drawer	990x465x600mm	\$404.00	\$POA
FS4036	Filing Cabinet - 4 drawer	1300x465x600mm	\$478.00	\$POA

Code: FS4036
Lockable



Credenza Unit

Lockable
Sliding Doors



Code	Description	Dimensions (WxHxD)	Price Each	
			1-9	10+
FS4037	Credenza	1200x730x450mm	\$310.00	\$POA
FS4038	Credenza	1500x730x450mm	\$350.00	\$POA
FS4039	Credenza	1800x730x450mm	\$400.00	\$POA

Credenza Unit is not available in grey

Boardroom Table (Boat Shape)



Code	Description	Dimensions (LxW)	Price Each	
			1-5	6+
FS4040	Boardroom (boat shape)	2400x1200mm	\$464.00	\$POA
FS4043	Boardroom (boat shape)	3000x1200mm	\$620.00	\$POA

Boardroom Table is not available in grey



Round Table

Code	Description	Price Each	
		1-9	10+
FS4041	Round Table - 900mm round	\$206.00	\$POA
FS4042	Round Table - 1200mm round	\$228.00	\$POA



Coffee Table

Code	Description	Price Each	
		1-5	6+
FS4044	Coffee Table 600x900mm	\$156.00	\$POA

Heavy Duty Industrial Storage Cabinets **STORMAX**

- These heavy duty industrial storage cabinets are made from reinforced sheet metal and are great for storing tools, parts and many other items in the workplace
- Full height cabinets come standard with 4 adjustable shelves and 1/2 height cabinet comes standard with 2 adjustable shelves
- Extra shelves can be purchased if required
- Optional drawer units can be purchased in either 100mm or 200mm deep
- Drawers come standard with adjustable dividers as pictured)
- Finish: Powdercoated light grey with light blue coloured doors



Full Height Cabinet

- Shelf Capacity: 150kgs
- 4 adjustable shelves as standard
- 3 point key lock system
- Optional drawer units available which fit inside unit so doors can be locked

Code: C8120



1/2 Height Cabinet

- Shelf Capacity: 150kgs
- 2 adjustable shelves as standard
- 3 point key lock system
- Option drawer units available which fit inside unit so doors can be locked

Code: C8121

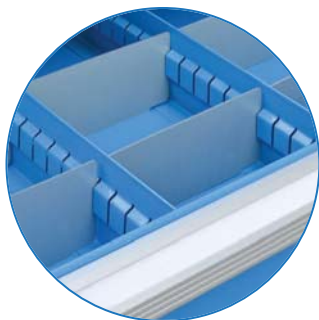

Drawer units come with these dividers

Code	Description	Dimensions	Price Each	2+
C8121	1/2 Height Industrial Cabinet	900x900x450mm (HxWxD)	\$298.00	\$POA
C8120	Full Height Industrial Cabinet	1800x900x450mm (HxWxD)	\$514.00	\$POA
C8123	Small Drawer Unit (fits inside cabinets)	100mm deep	\$120.00	\$POA
C8124	Large Drawer Unit (fits inside cabinets)	200mm deep	\$159.00	\$POA
C8144	Extra Shelves (to suit cabinets)	840x380x30mm (WxDxH)	\$39.50	\$POA

Industrial Tooling Cabinet

- These industrial tooling cabinets are a heavy duty drawer cabinet for industrial applications
- The 1/2 height industrial cabinet can be mounted on top of the tooling cabinet (as per image shown below)
- Finish: Powdercoated light grey with light blue coloured doors
- Drawer Capacity: 75kgs
- 4 x 100mm deep drawers
- 2 x 200mm deep drawers
- 3 point key lock system
- Drawers have adjustable dividers
- Dimensions: 900x900x450mm (HxWxD)



This image is shown with the C8122 on the bottom with C8121 mounted on top

Code	Description	Price Each	2+
C8122	Industrial Tooling Cabinet	\$796.00	\$POA



Industrial Tooling Cabinet on Wheels

- Heavy duty tooling cabinets, ideal for industrial applications and serious workshops
- The sliding drawers are a welded strengthened single rail design coupled with high quality mechanical bearings for long lasting smooth operation
- Each drawer is rated at 100kg load capacity with 97% drawer access
- Single key lock design for safe storage. Each drawer has a mechanical safety lock which allows one drawer to be opened at a time, preventing the cabinet from tipping over
- 2 fixed & 2 swivel 125mm castor wheels
- All drawers come with adjustable steel dividers
- Drawer Capacity: 100kg each
- Size: 565x580x900mm (WxDxH)
- 6 Drawers
 - 2 Drawers x 75mm
 - 2 Drawers x 100mm
 - 2 Drawers x 150mm
- Unit Weight: 100kg

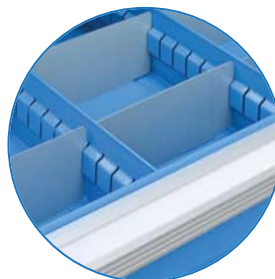

Code	Description	Price Each	2+
C8187	Industrial Tooling Cabinet on Wheels	\$765.00	\$POA

7 Drawer Industrial Tooling Cabinet

- Heavy duty tooling cabinets, ideal for heavy duty industrial applications
- The sliding drawers are a welded strengthened single rail design coupled with high quality mechanical bearings for long lasting smooth operation
- Each drawer is rated at 100kg load capacity with 97% drawer access
- Single key lock design for safe storage. Each drawer has a mechanical safety lock which allows one drawer to be opened at a time, preventing the cabinet from tipping over
- All drawers come with adjustable steel dividers
- Drawer Capacity: 100kg each
- Size: 881x653x1200xmm (WxDxH)
- Drawer 1 to 6 - 150mm high
- Drawer 7 - 200mm high
- Unit Weight: 100kg



Code	Description	Price Each	2+
C8125	Industrial Tooling Workstation	\$997.50	\$POA

Peg Board Tool Trolley

- Great tool trolley for general workshop use
- Comes with metal pegboard on back as well as the sides which can be used to hold tools and equipment
- 4 heavy duty castors (2 swivel and lockable and 2 fixed)
- Load Capacity: 250kg
- Finish: Powdercoated light grey
- Handle Height: 825mm



Trolley Dimensions

- Overall Width: 415mm
- Overall Length: 670mm
- Overall Height: 1730mm
- Back Panel Width: 605mm
- Back Panel Height: 440mm
- Top Shelf Height: 900mm
- Middle Shelf Height: 510mm
- Bottom Shelf Height: 160mm

Code	Description	Price Each	2+
T8186	Peg Board Tool Trolley	\$345.00	\$POA

Industrial Tooling Workstation

- Heavy duty tooling cabinets for industrial workshop applications
- The sliding drawers have quality smooth operation bearings
- 5 lockable drawers and cupboard
- The shelf as shown in the image is adjustable
- Draw Capacity: 100kg per drawer
- Finish: Powdercoated light grey and blue
- Bench Height: 950mm
- 2 lockable castors
- Fixed metal peg board panel which suits our range of hooks and accessories on the following page
- Dimensions: 1100x580x950mm (LxWxH)

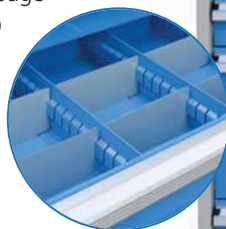

See page 255 for hooks and accessories

Code	Description	Price Each	2+
C8185	Industrial Tooling Workstation	\$930.00	\$POA

Heavy Duty Industrial Work Benches



- Heavy duty steel industrial work bench with optional peg board panel and lockable drawer set
- This work bench has a 1000kg top bench capacity
- Comes standard with adjustable feet for levelling on uneven floors however a castor kit is also available
- Finish: Powdercoated light grey
- Drawer Capacity: 100kg per drawer
- 2 drawer units available as shown in images
- Metal peg and louvre panel is great for storing parts bins and tools and bottom tray for additional off-bench storage space
- Work benches available in 1800mm and 2100mm long
- Back panel sets come with shelves and both square hole pegboard and louvre panel as pictured



5 Drawer Unit - Drawer Size Details	
Drawer No.	Drawer Depth
1 & 2	75mm
3 & 4	100mm
5 & 6	150mm



B8101C - Castor kit includes 4 of these castors



See page 255 for hooks and accessories



Images shown with optional back panel and drawer units

Code	Description	Dimensions	Price Each	2+
B8101	Industrial Work Bench - 1800mm	1800x750x900mm (LxWxH)	\$395.00	\$POA
B8102	Work Bench Back Panel Set (to suit B8101)	1735x205x825mm (LxWxH)	\$240.00	\$POA
B8107	Industrial Work Bench - 2100mm	2100x750x900mm (LxWxH)	\$435.00	\$POA
B8108	Work Bench Back Panel Set (to suit B8107)	2035x205x825mm (LxWxH)	\$264.00	\$POA
B8100	Work Bench 2 Drawer Unit	565x580x280mm (WxDxH) - 100mm drawers	\$195.00	\$POA
B8103	Work Bench 5 Drawer Unit	565x580x750mm (WxDxH)	\$595.00	\$POA
B8101C	Castor Kit to fit (includes 4 swivel castors with brakes)	raises bench by 80mm	\$184.00	\$POA

Heavy Duty Warehouse Packing Bench

- Strong heavy duty work or packing bench
- Rated to over 500kg capacity
- Timber board is 25mm MDF
- Bench Size: 2400x900x900mm (LxWxH)
- Bench is supplied flat packed
- Image shown with optional bottom shelf



Other bench configurations can be made to order

Code	Description	Price Each		
		1-2	3-5	6+
13560	Heavy Duty Packing Bench	\$395.00	\$355.00	\$POA
13562	Optional Bottom Shelf	\$89.00	\$80.00	\$POA

Louvre & Square Hole Panel Trolleys

- Strong metal panel trolleys which are ideal for storing either Stor-Pak bins or tools on hooks
- Fitted with 2 lockable castors
- Powdercoated grey colour
- Can be fitted one side with louvre panel and one side with square hole metal pegboard or a mix of both on each side on request
- Wheels can be removed to make fixed shelving if required
- Storpak bins and panel hooks are sold separately to the panel trolleys



Code: C8203 - Shelf to suit



See page 222 for Storpak bins

Code	Description	Dimensions	Price Each	
			1-3	4+
10730	Louvre Panel Trolley	980x600x1540mm (WxDxH)	\$585.00	\$POA
10735	Square Pegboard Panel Trolley	980x600x1540mm (WxDxH)	\$585.00	\$POA
C8203	Shelf to fit Panel Trolley	935x215mm (WxD)	\$39.00	\$POA

Louvre Panel & Square Hole Boards & Accessories

- These wall mountable panels are available with louvre panel slots or square pegboard holes for hanging items
- Panels can be mounted onto benches, walls, racking, shelving trolleys and more
- Large range of hanging hooks accessories available

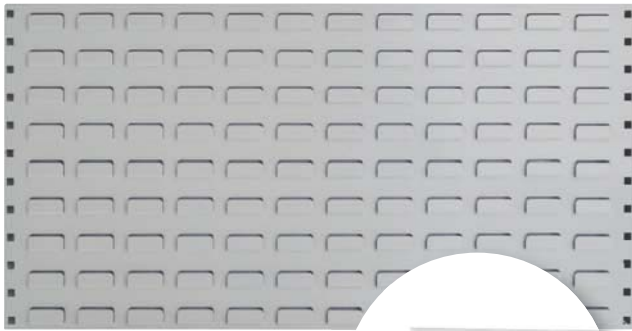

Code: C8200



Rear view

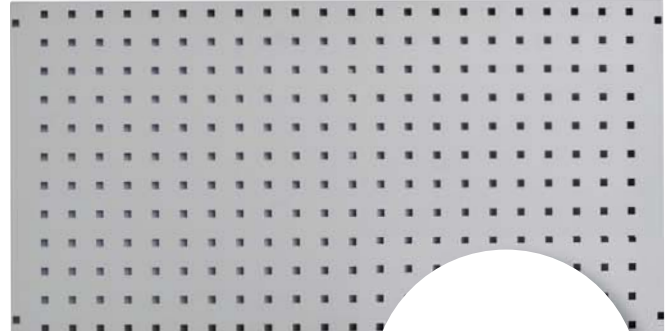

Code: C8201

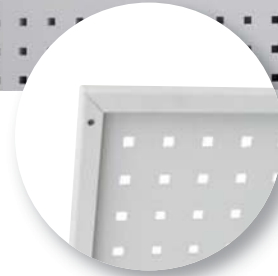

Rear view



C8204



C8205



C8206



C8207



C8208



C8210



C8209



C8211



C8212



C8213

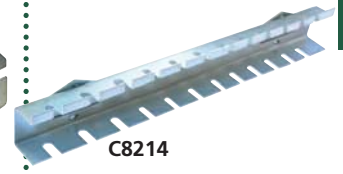

C8214

Code	Description	Dimensions	Price Each		
			1-49	50-99	100+
C8200	Metal Louvre Panel Board (Landscape)	900x455x20mm (WxHxD)	\$39.00	\$33.15	\$POA
C8201	Metal Square Hole Pegboard	900x455x20mm (WxHxD)	\$39.00	\$33.15	\$POA
C8204	Single Hook	25mm long	\$3.00	\$2.70	\$POA
C8205	Single Hook	75mm long	\$3.00	\$2.70	\$POA
C8206	Single Hook	150mm long	\$3.50	\$3.15	\$POA
C8207	Double Hook	25mm long	\$3.50	\$3.15	\$POA
C8208	Double Hook	75mm long	\$4.00	\$3.60	\$POA
C8209	U Shape Hook	23x35mm (LxW)	\$3.50	\$3.15	\$POA
C8210	U Shape Hook	70x25mm (LxW)	\$3.50	\$3.15	\$POA
C8211	3 Prong Hook	150mm long	\$5.90	\$5.30	\$POA
C8212	Round Hook	23x55mm	\$3.50	\$3.15	\$POA
C8213	Spanner Holder	135mm long	\$11.00	\$9.90	\$POA
C8214	Screwdriver Holder	390mm long	\$13.00	\$11.70	\$POA



CUSTOM MADE BENCHES

We can custom make work and packing benches to your particular requirements.
- Contact us for details and pricing

1800 750 900



Code: CB8105



Code: CB8104



Code: CB8107



Code: CB8106



Code: CB8108



Code: CB8109



Code: CB8110

Stainless Steel Benches

- Flat top work bench available in 600mm & 900mm depths
- 1.2mm thick 304 grade stainless steel top no. 4 finish
- 2mm heavy duty steel backing to work top with hat channel reinforcement
- 38mm diameter round stainless steel tube legs, satin polished, 1.2mm thick
- Adjustable nylon bullet feet supplied as standard
- 1mm thick galvanised steel under shelf
- Optional castor kits can be added to any work bench to make it mobile
- Optional additional under shelves are available
- Supplied flat packed ready for assembly



Price Each

Code	Description	Dimensions (Width x Depth x Height)	Legs	1-3	4+
SS1001	Stainless Steel Bench	600x600x900mm	4	\$290.15	\$POA
SS1002	Stainless Steel Bench	900x600x900mm	4	\$409.20	\$POA
SS1003	Stainless Steel Bench	1200x600x900mm	4	\$464.55	\$POA
SS1004	Stainless Steel Bench	1500x600x900mm	4	\$560.70	\$POA
SS1005	Stainless Steel Bench	1800x600x900mm	6	\$692.75	\$POA
SS1006	Stainless Steel Bench	2100x600x900mm	6	\$707.40	\$POA
SS1007	Stainless Steel Bench	2400x600x900mm	6	\$862.25	\$POA
SS1008	Stainless Steel Bench	900x900x900mm	4	\$404.20	\$POA
SS1009	Stainless Steel Bench	1200x900x900mm	4	\$493.90	\$POA
SS1010	Stainless Steel Bench	1500x900x900mm	4	\$583.50	\$POA
SS1011	Stainless Steel Bench	1800x900x900mm	6	\$718.80	\$POA

Stainless Steel 4 Tier Shelving Sets

- Constructed from 304 grade stainless steel
- Includes 4 adjustable shelves
- Shelves are 1.2mm thick and fully welded for extra strength
- 41mm diameter round stainless steel tube legs, satin polished, 1.2mm thick
- Adjustable nylon bullet feet supplied as standard
- Shelves are reinforced with hat channel for extra strength
- Supplied flat packed ready for assembly



Price Per Set

Code	Description	Dimensions (Width x Depth x Height)	1-4 Sets	5+
SS1050	Stainless Steel 4 Tier Shelving Set	600x450x1800mm	\$552.00	\$POA
SS1051	Stainless Steel 4 Tier Shelving Set	900x450x1800mm	\$617.00	\$POA
SS1052	Stainless Steel 4 Tier Shelving Set	1200x450x1800mm	\$785.00	\$POA
SS1053	Stainless Steel 4 Tier Shelving Set	1500x450x1800mm	\$939.00	\$POA

Heavy Duty Filing Cabinets

- Versatile, functional & practical steel filing cabinets available in 2, 3 and 4 drawer to suit your individual requirements
- Supplied fully assembled
- All our filing cabinets have anti-tilt safety device
- Filing cabinets are key lockable
- Available in light grey, beige and black colours

Colours Available



Price Each

Code	Description	Dimensions (Width x Height x Depth)	1-4	5-9	10+
10157	2 Drawer Filing Cabinet	465x720x620mm	\$202.40	\$183.70	\$POA
10158	3 Drawer Filing Cabinet	465x1020x620mm	\$258.50	\$235.40	\$POA
10159	4 Drawer Filing Cabinet	465x1320x620mm	\$314.60	\$286.00	\$POA

*Please specify colour preference when placing your order (light grey, beige or black)

Heavy Duty Stationery Cupboards

- Versatile, functional & practical steel office cabinets which allow freedom to create & configure storage areas to suit your individual requirements
- Supplied fully assembled
- All cupboards are key lockable
- Available in 1/2 height and full height sizes
- Available in light grey and beige colours as pictured

Colours Available



Price Each

Code	Description	Dimensions (Width x Height x Depth)	1-4	5-9	10+
10151	Half Height Stationery Cabinet (includes 1 shelf)	920x915x450mm	\$268.40	\$225.50	\$POA
10152	Full Height Stationery Cabinet (includes 3 shelves)	920x1830x450mm	\$328.90	\$303.60	\$POA
10153	Extra Shelf to suit Stationery Cabinet	-	\$32.50	\$29.25	\$POA

*Please specify colour preference when placing your order (light grey or beige)

4 Drawer Fire Resistant Filing Cabinets

- Tested and proven to withstand temperatures up to 900 degrees for one hour
- 4 drawer capacity
- High quality steel sliders in all cabinets to ensure smooth operation and full drawer access
- Available in 1/2 height and full height sizes
- Key lockable
- Available in light grey colour as pictured



Code	Description	Dimensions (Width x Height x Depth)	Price Each	2+
10160	Fire Resistant Filing Cabinet	515x1549x755mm	\$1840.00	\$POA

Heavy Duty Personal Lockers

- Ideal for the secure storage of personal items for employees and visitors etc
- Available in 5 different configurations as standard however other sizes and configurations can be made to order
- 2 standard widths available (305 & 380mm)
- Reinforced doors for increased strength and security
- Ventilation louvers are fitted to all doors
- Choice of key or padlock lockable
- Manufactured from powdercoated steel
- 10 year warranty
- Colour: Standard is light grey however other colours are available on request



Padlock Lockable



Key Lockable



Sloping tops available on request



We can supply locker stands for any bank of lockers - please contact us for pricing

Code	Description	Dimensions (Width x Depth x Height)	Colour	Price Each	
				1-3	4+
PL1003	Personal Locker (1 door)	305x457x1830mm	Light Grey	\$243.10	\$POA
PL1001	Personal Locker (1 door)	380x457x1830mm	Light Grey	\$258.00	\$POA
PL1005	Personal Locker (2 door)	305x457x1830mm	Light Grey	\$251.60	\$POA
PL1002	Personal Locker (2 door)	380x457x1830mm	Light Grey	\$270.30	\$POA
PL1007	Personal Locker (3 door)	305x457x1830mm	Light Grey	\$275.00	\$POA
PL1008	Personal Locker (3 door)	380x457x1830mm	Light Grey	\$278.00	\$POA
PL1009	Personal Locker (4 door)	380x457x1830mm	Light Grey	\$306.00	\$POA
PL1010	Personal Locker (6 door)	305x457x1830mm	Light Grey	\$324.70	\$POA
PL1011	Personal Locker (6 door)	380x457x1830mm	Light Grey	\$343.40	\$POA

Please specify lock type when placing your order (padlock or key)

Premium Office Gas Lift Chairs

- Premium quality office gas lift chairs to suit every need
- 4 chairs come with a choice of fabric colours as pictured below
- The C1103 draftsman chair has a choice of castors or nylon floor glides



Code: C1100



Code: C1101



Code: C1102



Code: C1103



Burgundy



Charcoal



Navy



Black

The four chairs pictured above, have a choice of 4 fabric colours. Please specify your preferred choice when placing your order.



Code: C1104



Code: C1105



Code: C1106



Code: C1107

Price Each

Code	Description	Colours Available	1-3	4+
C1100	Typist Chair	*Burgundy, Charcoal, Navy, Black	\$184.00	\$POA
C1101	Computer Chair	*Burgundy, Charcoal, Navy, Black	\$240.00	\$POA
C1102	Clerical Chair (with arms)	*Burgundy, Charcoal, Navy, Black	\$299.00	\$POA
C1103**	Draftsmans Chair (with foot rest surround)	*Burgundy, Charcoal, Navy, Black	\$268.00	\$POA
C1104	Office Chair (with airpump lumbar support & arms)	Black	\$429.00	\$POA
C1105	Executive Chair (with arms & headrest)	Black	\$469.00	\$POA
C1106	Managers Chair (with mesh back & arms)	Black	\$379.00	\$POA
C1107	Executive Chair (with mesh back, arms & headrest)	Black	\$488.00	\$POA

*Please specify your preferred fabric colour when placing your order

**Code number #C1103 has a choice of castors or nylon glides (please specify when placing your order)

Workplace Industrial Seating

- This seating is designed to withstand hard use, moisture and chemicals in the industrial environment
- Ideal for workplace environments such as factory production lines, clean rooms, workshops and laboratories
- Easy clean polyurethane or industrial vinyl seats and backrests
- Gas lift chairs are available with glide feet or standard castors



Code	Description	Height Adjustment	Price Each	
			1-3	4+
C1200*	Polyurethane Saddle Seat	420-620mm	\$215.00	\$POA
C1201*	Polyurethane Stool (with foot rest surround)	590-840mm	\$285.00	\$POA
C1202*	Polyurethane Chair	460-660mm	\$245.00	\$POA
C1203*	Polyurethane Round Seat (with foot rest surround)	590-840mm	\$185.00	\$POA
C1204*	Polyurethane Round Seat	420-620mm	\$165.00	\$POA
C1205	Visitors Chair (with padded seat & back)	-	\$163.00	\$POA

*These chairs have a choice of castors or nylon glides (please specify when placing your order)

Aluminium Tables & Seating

- Aluminium seating is great for schools, playgrounds workplace lunch areas etc
- This is our standard range below however other sizes and configurations can be made to order
- Standard colour legs and end caps supplied is plain aluminium however a choice of colours is available as listed



Code: A2000



Code: A2010



Code: A2020



Code: A2030



Code: A2040
(shown with green legs & end caps)



Code: A2050
(shown with green legs & end caps)

Leg & End Cap Colours Available (please contact us for pricing on colours)



Price Per Set

Code	Description	Table Top Size (Width x Length)	Legs/End Caps Colour	1-2 Sets	3+ Set
A2000	Aluminium Seating Set	1000x1000mm	Plain Aluminium	\$1438.20	\$POA
A2010	Aluminium Seating Set	750x2000mm	Plain Aluminium	\$1198.00	\$POA
A2020	Aluminium Seating Set	1000x2000mm	Plain Aluminium	\$1746.00	\$POA
A2030	Aluminium Seating Set	750x2000mm	Plain Aluminium	\$1538.00	\$POA
A2040	Aluminium Seating Set	750x2000mm	Plain Aluminium	\$1198.00	\$POA
A2050	Aluminium Seating Set	750x2000mm	Plain Aluminium	\$1215.00	\$POA

Aluminium Plain Bench Seats

- Aluminium plain bench seats are great for schools, Tafes, Universities, playgrounds, workplace lunch areas etc
- This is our standard range below however other sizes and configurations can be made to order
- Choice of lengths available from 1.5 meters to 6 metres



Code	Description	Length	Price Each	
			1-2	3+
A3105	Aluminium Plain Bench Seat	1500mm	\$251.00	\$POA
A3106	Aluminium Plain Bench Seat	2000mm	\$285.00	\$POA
A3107	Aluminium Plain Bench Seat	3000mm	\$413.00	\$POA
A3108	Aluminium Plain Bench Seat	4000mm	\$482.00	\$POA
A3109	Aluminium Plain Bench Seat	6000mm	\$678.00	\$POA



Code	Description	Length	Price Each	
			1-2	3+
A3205	Aluminium Bench & Backrest	1500mm	\$478.00	\$POA
A3206	Aluminium Bench & Backrest	2000mm	\$572.50	\$POA
A3207	Aluminium Bench & Backrest	3000mm	\$821.00	\$POA
A3208	Aluminium Bench & Backrest	4000mm	\$937.00	\$POA
A3209	Aluminium Bench & Backrest	6000mm	\$1299.00	\$POA

Aluminium Stackable Seating

- Aluminium stackable bench seats are great for schools, Tafes, Universities, playgrounds, workplace lunch areas etc
- Ideal for special occasions as they can be packed up and put in storage
- Choice of lengths available from 1.5 meters to 6 metres



Leg & End Cap Colours Available (please contact us for pricing on colours)



Code	Description	Length	Seat Height	Colour	Price Each	
					1-2	3+
A3250	Aluminium Stackable Seating	1500mm	300 or 400mm	Plain Aluminium	\$280.50	\$POA
A3251	Aluminium Stackable Seating	2000mm	300 or 400mm	Plain Aluminium	\$313.65	\$POA
A3252	Aluminium Stackable Seating	3000mm	300 or 400mm	Plain Aluminium	\$456.00	\$POA
A3253	Aluminium Stackable Seating	4000mm	300 or 400mm	Plain Aluminium	\$525.00	\$POA
A3254	Aluminium Stackable Seating	6000mm	300 or 400mm	Plain Aluminium	\$735.60	\$POA

*Please specify your preferred seat height when placing your order (eg, A3250-300mm or A3250-400mm)

Counting Scales

- 20mm digit height LCD, white colour LED backlight
- 20 keys embossed membrane keyboard
- Function includes quantity checking alarm and checking weighing, auto unit weight update
- Battery provides up to 90 hours of continuous use
- Rechargeable battery & power option
- Platform Size: 230x300mm (DxW)
- Capacity: 30kg
- Increments: 1 gram
- 12 Months warranty



Code	Description	Price Each	2+
S3210	Counting Scale	\$507.00	\$POA

Weighing Scales

- 20mm Digit Height LCD, white colour LED Backlight
- Battery provides up to 90 hours of continuous use
- Rechargeable battery & power option
- Unit Weight: 19kg
- Capacities: 30, 60 & 150kgs
- Weighing indicator can be benched mounted
- 12 Months warranty



Code	Description	Platform Size (DxW)	Increments	Price Each	2+
S3211	Weighing Scale 30kg	400x300mm	2 grams	\$629.00	\$POA
S3212	Weighing Scale 60kg	500x400mm	5 grams	\$682.00	\$POA
S3213	Weighing Scale 150kg	500x400mm	10 grams	\$682.00	\$POA

Table Scales

- 52mm LCD Display , white colour LED Backlight
- 20 Keys embossed membrane Keyboard
- Function includes units conversion, parts counting percentage weighing, accumulation, nett/gross shift
- Battery provides up to 90 hours of continuous use
- Rechargeable battery and built & power option
- Platform Size: 240x370mm (DxW)
- Capacities: 15, 30 & 45kg
- 12 Months warranty



Code	Description	Increments	Price Each	2+
S3215	Weighing Scale 15kg	0.5 grams	\$598.00	\$POA
S3216	Weighing Scale 30kg	1 gram	\$598.00	\$POA
S3217	Weighing Scale 45kg	1 gram	\$643.50	\$POA

Stainless Steel Portion Scales

- Standard Long-life 9V battery for portability
- All food grade stainless steel housing
- Compact design for precious table space
- Unit conversion available
- Auto-off function for power saving
- Supplied with 12-15 VDC/500mA power adaptor
- NSC (Approval No: 6/4C/226) and OIML Approved
- Platform Size: 180x240mm (DxW)
- 12 Months warranty



Code	Description	Increments	Price Each	2+
S3218	Portion Scale 1kg	1 gram	\$460.00	\$POA
S3219	Portion Scale 2kg	2 grams	\$460.00	\$POA
S3220	Portion Scale 5kg	5 grams	\$460.00	\$POA

Stainless Steel Waterproof Scales



- Wash down design
- Completely stainless steel housing
- Red LED display
- 1/6,000, 1/15,000 display division selectable
- KG/LB selectable weighing mode
- HI/LO/OK weight checking with choice of variety alarm
- Weight and times accumulation, full tare, pre-tare, zero tracking, keyboard calibration,
- Auto power off selectable
- Easily adjusted levelling feet for stability of the scale
- Platform Size: 190x230mm
- Scale operates fully submerged under water!

Code	Description	Increments	Price Each	2+
S3221	S/S Waterproof Scale 3kg	0.5 grams	\$442.00	\$POA
S3222	S/S Waterproof Scale 6kg	1 gram	\$442.00	\$POA
S3223	S/S Waterproof Scale 15kg	2 grams	\$442.00	\$POA
S3224	S/S Waterproof Scale 30kg	5 grams	\$442.00	\$POA

Shipping / Parcel Scales

- Low profile design
- Rigid construction
- Remote display unit for weighing ease
- Hold or net / gross function
- Unit conversion available (KG/LB/OZ)
- Large and bright easy-to-read LCD display
- Auto-off function for power saving in seconds (120, 180, 240, 360, off optional)
- Rechargeable Battery and AC adaptor supplied
- Function Keys: Zero, Tare, Hold, Unit, On/Off



Code	Description	Dimensions	Increments	Price Each	2+
S3230	Parcel Scale 30kg	310x310mm	10 grams	\$286.00	\$POA
S3260	Parcel Scale 60kg	405x355mm	20 grams	\$312.00	\$POA

Stainless Platform Scales

- Check weighing indicator
- Internal Resolution: 1/600,000
- Large LCD display with backlight
- Application Programs: accumulation, animal scale check weighing
- Battery power and AC power supply
- Fully stainless steel
- Platform Size: 400x500mm (WxD)



Code	Description	Capacity	Increments	Price Each	2+
S3227	S/S Platform Scales	60kg	10 grams	\$1813.50	\$POA
S3228	S/S Platform Scales	150kg	20 grams	\$1813.50	\$POA



Price Computing Scales

- Ideal for use in fruit shops, butchers, deli's etc
- Internal resolution: 1/300,000
- Double side pole display
- Application Programs: Price computing, preset tare, accumulation, unit conversion
- Battery provide up to 90 hours of continuous use
- Supplied with AC power adaptor
- Dual Increments
- Platform Size: 230x300mm
- Trade approved!

Code	Description	Increments	Price Each	2+
S3231	Price Scale 6kg	1 / 2 grams	\$495.00	\$POA
S3232	Price Scale 15kg	2 / 5 grams	\$495.00	\$POA
S3233	Price Scale 30kg	5 / 10 grams	\$495.00	\$POA

Hanging Scales

- Standard 20mm LCD display
- Programs Include zero and tare function
- Overload alarm to warn if have gone over the capacity
- Battery indication function to warn you of the current battery power level
- Waterproof front panel buttons

Code	Description	Increments	Price Each	2+
S3240	Hanging Scale 30kg	10 grams	\$286.00	\$POA
S3241	Hanging Scale 100kg	50 grams	\$286.00	\$POA
S3242	Hanging Scale 200kg	100 grams	\$286.00	\$POA
S3243	Hanging Scale 300kg	100 grams	\$325.00	\$POA



Crane Scales

- LCD Display backlight
- Programs Include zero and tare function
- Overload alarm to warn if have gone over the capacity
- Battery indication function to warn you of the current battery power level
- Uses AA Battery (not provided)
- Auto Power off



Code	Description	Capacity	Increments	Price Each	2+
S3246	Crane Scales	500kg	200 grams	\$643.50	\$POA
S3247	Crane Scales	1000kg	500 grams	\$832.00	\$POA

Display Unit



Floor Pallet Scales

- Great for weighing pallets and large bulky and heavy items
- Platform Size: 1200x1200mm
- Capacity: 2000 and 3000kg available
- Adjustable levelling feet for uneven ground
- Can be pit mounted so that it sits flush with the ground
- Low Profile 70mm height from ground level
- Construction: Mild Steel
- Power Supply: 240V

Code	Description	Capacity	Increments	Price Each	2+
PS2000	Floor Pallet Scale	2000kg	0.5 kilo	\$1960.00	\$POA
PS3000	Floor Pallet Scale	3000kg	0.5 kilo	\$2295.00	\$POA

2000KG Pallet Truck With Load Scales

Our scale pallet trucks are extremely reliable and highly accurate in measuring your pallet weight. This fork truck has a totalising function which adds up multiple pallet weights giving the total weight per shipment or order.

- The weighing unit uses four AA batteries which give approx 4200 weighting actions
- The unit gives a low battery warning and shuts off after 3 minutes
- The digital display can be read from any angle in ambient light conditions
- Optional scale printer unit available on request
- Capacity: 2000kg
- Scale Increments: 1kg
- Scale Functions: Zero correction, gross/net weight, total weight
- Overall Fork Width: 690mm
- Minimum Fork Height: 76mm
- Overall Fork Length: 1220mm
- Overall Truck Length: 1650mm
- Tine Size: 50x182mm
- Steering Wheel Size: 50x180mm



Code	Description	Price Each	2+
T7221	Pallet Truck With Load Scales	\$1999.00	\$POA

Light Weight Expanding Barrier

- Portable, lightweight and durable
- Built-in handle and locking strap for ease of handling
- Corrosion resistant
- Use indoors or outdoors
- Safety yellow and black plastic construction
- Injection moulded ABS plastic
- Height: 970mm without castors (open)
- Width: 2.4 metres expanded (250mm closed)
- Weight: 3kg (boxed)



Code	Description	Price Each	
		1-3	4+
B3705	Light Weight Expanding Barrier	\$162.80	\$POA



Expanding Barrier

- Wider 400mm feet for increased stability
- Wall receiver and sign brackets included
- Open Height without castors: 990mm
- 3m Barrier closed is: 325mm
- 6m Barrier closed is: 625mm
- Aluminium and high-tech plastic construction
- Available in two colour combinations
- Available with optional castor kit as shown in photo (see accessories)
- Made from powder coated aluminium and high-tech plastics

Price Each

Code	Description	Size	Colour	1-3	4+
B3610	Expanding Barrier	3 metre	Red/White	\$347.60	\$POA
B3611	Expanding Barrier	3 metre	Black/Yellow	\$347.60	\$POA
B3612	Expanding Barrier	6 metre	Red/White	\$495.00	\$POA
B3613	Expanding Barrier	6 metre	Black/Yellow	\$495.00	\$POA

Flexi Expanding Barrier

- Ability to expand out to 5.4 metres
- Pivots at the middle through 270 degrees
- Can step up to 300mm for changing floor levels
- Available in Red/White or Black/Yellow
- Made from powder coated aluminium and high-tech plastics
- Compact design, weighs 9.2kgs
- Width when closed 300mm
- Width when fully extended 2 x 2700mm
- Range of accessories available
- Wall receiver and sign brackets included



Price Each

Code	Description	Size	Colour	1-3	4+
B3601	Expanding Barrier	2 x 2.7 metres	Red/White	\$495.00	\$POA
B3602	Expanding Barrier	2 x 2.7 metres	Black/Yellow	\$495.00	\$POA

Utility Expanding Barrier

- Consists of three sides that can each expand out to 2.6 metres
- Available in Red/White or Black/Yellow
- Compact design, weighs 17kgs
- Width when closed 360mm
- Width when fully extended 3 x 2600mm
- Designed for cordoning off small spaces
- Made from powder coated aluminium and high-tech plastics
- Spare parts and accessories available
- Wall receiver and sign brackets included



Price Each

Code	Description	Size	Colour	1-3	4+
B3625	Expanding Barrier	3 x 2.6 metres	Red/White	\$692.00	\$POA
B3626	Expanding Barrier	3 x 2.6 metres	Black/Yellow	\$692.00	\$POA

Expanding Barrier Accessories

- Range of accessories to suit the red/white and black/yellow expanding barriers



Signs can be inserted back to back for double sided viewing



Mounting Post



Wall/Sign Mount Bracket



Lockable Castors



Wall Receiver

Price Each

Code	Description	1-9	10+
B3710	Mounting Post (suits all except the light weight barrier B3705)	\$187.00	\$POA
B3711	Wall/Sign Mount Bracket	\$8.80	\$POA
B3712	A4 Sign Pocket (requires B3711 to mount to barrier)	\$39.60	\$POA
B3713	A5 Sign Pocket (requires B3711 to mount to barrier)	\$24.20	\$POA
B3714	Lockable Castor (fits plastic feet) - Each	\$28.60	\$POA
B3715	Wall Receiver	\$8.80	\$POA

Large Maxi Expanding Barrier

- Complete with four heavy duty locking castors
- Non-corrosive construction for outdoor use
- Increased safety and security due to reduced opening sizes
- Can be linked together to form a continuous heavy duty barrier
- Easily transported by one person
- Available in 2 different heights
- Finished: Natural Aluminium
- Hot dip galvanised slide guides
- Stainless steel assembly fittings
- Width of barrier when closed: 580mm
- The heights listed below are from the ground to the top of the slats

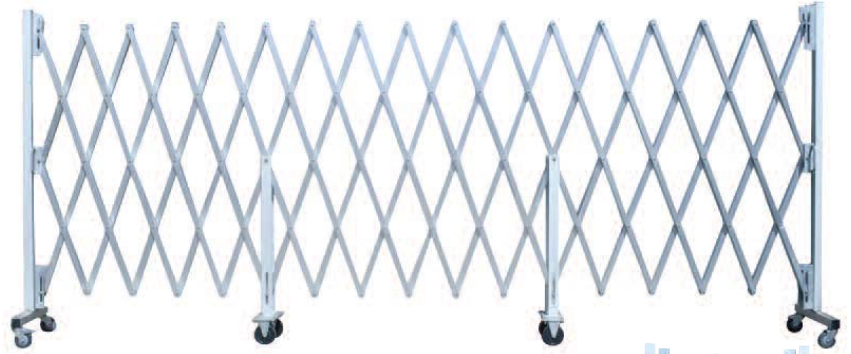

Wall Receiver Bracket

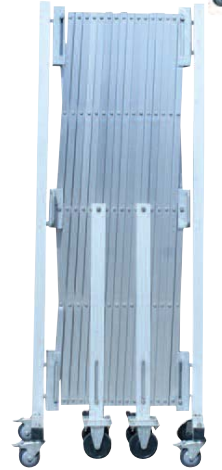

Price Each

Code	Description	Height	Overall Length	Unit Weight	1-3	4+
B6700	Large Maxi Expanding Barrier	1430mm	6700mm	32.2kg	\$1315.00	\$POA
B6702	Large Maxi Expanding Barrier	1800mm	7800mm	40kg	\$1955.00	\$POA
B6701	Wall Receiver Bracket				\$17.60	\$POA

Pedestrian Event Control Fence



Event Fence portable barrier is a system of interlocking freestanding fence panels. Simply link Event Fence panels together to create continuous barricading for festivals, parades, sporting events or work sites. Optional forklift stillage makes storage and transporting of Event fence panels simple and efficient.

Fence Specifications

- Fully welded steel construction, galvanised finish
- Panels nest together when not in use to reduce storage space
- Vertical bars eliminate climbing points
- Panels are able to pivot at joints
- Low profile, removable feet reduces tripping hazards
- Height: 1100mm
- Length: 2200mm
- Width: 490mm
- Weight: 16kg

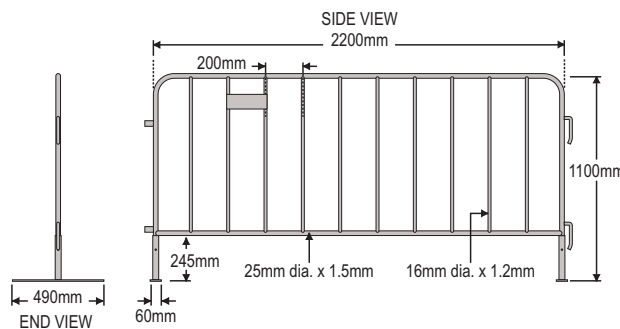

Freestanding panels, link together
No tools required



Price Each

Code	Description	1-9	10+
B6710	Event Fence Barrier Panel	\$185.00	\$POA
B6711	Event Fence Stillages (holds 30 panels)	\$489.00	\$POA

Portable Ecoline Belt Post Barrier







The Econoline is our most affordable portable post and base belt barrier, offering an economical alternative to the high end Highline models. The weighted base is covered with a polished stainless steel skirt for a quality finish. The base has built-in scuff pads to protect sensitive floors. Furthermore, the NBEL is compatible with our other belt barriers, as it uses the same belt cassettes.

Specifications

- Post: 304 stainless, 63 x 0.8 x 950mm high
- Base: Weighted with stainless skirt
- Base Size: 330mm diameter
- Portable freestanding
- Retractable 2 metre 4-way
- Weight: 8kg



Price Each

Code	Description	Belt Colour	1-5	6+
B3421	Portable Ecoline Post Barrier	Black 	\$176.00	\$POA
B3422	Portable Ecoline Post Barrier	Blue 	\$176.00	\$POA
B3423	Portable Ecoline Post Barrier	Red 	\$176.00	\$POA
B3424	Portable Ecoline Post Barrier	Yellow 	\$176.00	\$POA
B3425	Portable Ecoline Post Barrier	Burgundy 	\$176.00	\$POA
B3426	Portable Ecoline Post Barrier	Black/Yellow 	\$176.00	\$POA
B3427	Portable Ecoline Post Barrier	Red/White 	\$176.00	\$POA



Portable Highline Belt Post Barrier

Highline is our most popular portable post and base belt barrier. The moulded rubber base is covered with a 304 grade spun stainless steel skirt for a high quality finish. The non-marking rubber base is gentle on floors and makes the post extremely stable.

Specifications

- Post: 304 stainless, 63 x 1.6 x 950mm high
- Base: Moulded rubber with stainless skirt
- Base Size: 380mm diameter
- Portable freestanding
- Retractable 2 metre 4-way
- Weight: 10.5kg

Price Each

Code	Description	Belt Colour	1-5	6+
B3410	Portable Highline Post Barrier	Black 	\$284.00	\$POA
B3411	Portable Highline Post Barrier	Blue 	\$284.00	\$POA
B3412	Portable Highline Post Barrier	Red 	\$284.00	\$POA
B3413	Portable Highline Post Barrier	Yellow 	\$284.00	\$POA
B3414	Portable Highline Post Barrier	Burgundy 	\$284.00	\$POA
B3415	Portable Highline Post Barrier	Black/Yellow 	\$284.00	\$POA
B3416	Portable Highline Post Barrier	Red/White 	\$284.00	\$POA



Portable Extreme Belt Post Barrier

The Extreme is the perfect retractable belt barrier for tough, industrial-type environments. The UPVC post with moulded rubber base means the Extreme can be used indoors or outdoors in any conditions and is incredibly stable. The non-marking rubber base is gentle on floors.

Specifications

- Post: Yellow UPVC, 63 x 1.6 x 950mm high
- Base: Moulded rubber
- Base Size: 380mm diameter
- Portable freestanding
- Retractable 2 metre 4-way
- Weight: 8.5kg



Code	Description	Belt Colour	Price Each	
			1-5	6+
B3436	Portable Extreme Post Barrier	Black/Yellow 	\$189.00	\$POA
B3437	Portable Extreme Post Barrier	Red/White 	\$189.00	\$POA









Wall Mount Retractable Barrier

Wall mount belt barriers are designed to complement other post units in our range, or to be used as standalone barriers for aisle closures or supermarket checkouts etc. They use the same 2 metre belt cassettes as the posts in a welded 316 grade stainless steel body, with mounting brackets for attaching to a wall or post.

Specifications

- Housing: 316 stainless, 63 x 1.6 x 160mm high
- Connection: Wall or post mount
- Portable freestanding
- Retractable 2 metre 1-way
- Weight: 1.3kg

Price Each

Code	Description	Belt Colour	Price Each	
			1-5	6+
B3441	Wall Mount Retractable Barrier	Black 	\$129.00	\$POA
B3442	Wall Mount Retractable Barrier	Blue 	\$129.00	\$POA
B3443	Wall Mount Retractable Barrier	Red 	\$129.00	\$POA
B3444	Wall Mount Retractable Barrier	Yellow 	\$129.00	\$POA
B3445	Wall Mount Retractable Barrier	Burgundy 	\$129.00	\$POA
B3446	Wall Mount Retractable Barrier	Black/Yellow 	\$129.00	\$POA
B3447	Wall Mount Retractable Barrier	Red/White 	\$129.00	\$POA

Wall Belt Receiver

- Wall receivers allow belts to be terminated at any wall or post etc
- All our belt posts and wall mount belt barriers are compatible with these wall receivers
- They are injection moulded from black nylon and attached with two self-tapping screws provided

Price Each

Code	Description	Price Each	
		1-3	4+
B3449	Metal Wall Belt Receiver Bracket	\$18.00	\$POA



Portable Highline Rope Post Barrier

Highline is our most popular selling portable post and base barrier. The moulded rubber base is covered with a 304 grade spun stainless steel skirt for a high quality finish. The non-marking rubber base is gentle on floors and make the post extremely stable.

Specifications

- Post: 304 stainless, 63 x 1.6 x 950mm high
- Base: Moulded rubber with stainless skirt
- Base Size: 380mm diameter
- Portable freestanding
- 2 or 4 way snap hooks
- Weight: 10.5kg







Code	Description	Type	Price Each	
			1-5	6+
B3491	Portable Rope Post Barrier	2 Way	\$239.00	\$POA
B3493	Portable Rope Post Barrier	4 Way	\$239.00	\$POA

Braided Ropes for Rope Post Barrier



A selection of high quality braided ropes in a range of colours with machined stainless steel end ferrules. Our standard ropes are made to suit 2 metre post centres, however custom made ropes can be made in any length up to 2.5 metres.

Code	Description	Belt Colour	Price Each	
			1-5	6+
B3494	2m Braided Rope	Black 	\$115.00	\$POA
B3495	2m Braided Rope	Blue 	\$115.00	\$POA
B3496	2m Braided Rope	Red 	\$115.00	\$POA
B3497	2m Braided Rope	Burgundy 	\$115.00	\$POA

Wall Hook Receiver for Braided Ropes

- Wall receivers allow ropes and chains to be terminated at any wall or post etc
- All our braided ropes and chains are compatible with these wall receivers
- They are injection moulded from black nylon and are attached with two self tapping screws provided

Code	Description	Price Each	
		1-3	4+
B3498	Wall Receiver (for braided ropes)	\$16.00	\$POA



Retractable Tape Barrier

- Full 9 metre retractable tape
- Push button tape lock to prevent tampering
- Tough, corrosion proof moulded housing
- Four way connectivity
- Unique belt clip allows belt to hook back onto itself
- Fits standard 1 metre traffic cones or UPVC posts
- High visibility Red/White or Black/Yellow tape
- Wall mount bracket available (see accessories)
- Optional emergency light (see accessories)
- Optional sign holders and signs (see accessories)
- Housing – High impact polypropylene
- Tape – Reinforced nylon with water repellent coating
- Tape Length: 9 metres
- Housing Size: 250mm high, 150mm in diameter
- Unit Weight: 880g



Price Each

Code	Description	Colour	1-5	6+
B3810	Retractable Barrier - 9 metre	Red/White	\$279.00	\$POA
B3811	Retractable Barrier - 9 metre	Black/Yellow	\$279.00	\$POA
B3812	Retractable Barrier Post - (makes belt height 990mm)	Yellow Post	\$145.00	\$POA

Retractable Tape Barrier Accessories



Wall Mount Bracket



Sign Holder



Receiver Bracket



Rechargeable LED warning light powered by 6 AA batteries and switchable between permanent or flashing mode



1 metre high stackable cone



Cone 2 way receiver unit

Price Each

Code	Description	Specifications	1-5	6+
B3820	Wall Mount Bracket	can be mounted to walls and columns	\$52.70	\$POA
B3821	Sign Holder Bracket	for use with A4 sign holder #B3822	\$18.70	\$POA
B3822	A4 Sign Holder Assembly	requires B3821 to mount to barrier unit	\$52.00	\$POA
B3823	Wall Receiver Bracket	anodised aluminium	\$16.00	\$POA
B3824	Rechargeable LED Light Unit	requires 6 x AA batteries (not supplied)	\$196.00	\$POA
B3825	Stackable Cone 1 metre high	used to mount the barrier unit	\$46.00	\$POA
B3826	2 Way Cone Receiver Unit	fits the B3825 cones	\$62.00	\$POA





Wall Mount Retracta-Belt

- Material: High-impact polycarbonate housing
- Extension: 0 - 7.6 metres
- Supplied: Complete with fixings and wall receiver end
- Belt: Available in 5 standard colours
- Installation: Permanent, screw fixed

Belt Colours Available



Price Each

Code	Description	Belt Colour	1-5	6+
B3831	Retracta Belt 7.6 metres	Black/Yellow 	\$375.00	\$POA
B3832	Retracta Belt 7.6 metres	Red/White 	\$375.00	\$POA
B3833	Retracta Belt 7.6 metres	Black 	\$375.00	\$POA
B3834	Retracta Belt 7.6 metres	Yellow 	\$375.00	\$POA
B3835	Retracta Belt 7.6 metres	Red 	\$375.00	\$POA
B3836	Additional Wall Receiver	-	\$25.90	\$POA



Magnet Mount Retracta-Belt



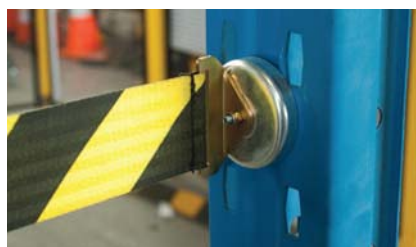

- Material: High-impact polycarbonate housing
- Extension: 0 - 7.6 metres
- Supplied: Complete with magnetic base and belt clip
- Belt: Available in 5 standard colours
- Installation: Semi-Permanent magnetic fixed

Belt Colours Available



Magnetic end piece which forms a fixed barrier point

Price Each

Code	Description	Belt Colour	1-5	6+
B3840	Magnet Mount Retracta Belt 7.6 metres	Black/Yellow 	\$486.00	\$POA
B3841	Magnet Mount Retracta Belt 7.6 metres	Red/White 	\$486.00	\$POA
B3842	Magnet Mount Retracta Belt 7.6 metres	Black 	\$486.00	\$POA
B3843	Magnet Mount Retracta Belt 7.6 metres	Yellow 	\$486.00	\$POA
B3844	Magnet Mount Retracta Belt 7.6 metres	Red 	\$486.00	\$POA

Fixed Yellow Bollards

- Ideal for protecting expensive equipment and racking from possible forklift damage
- Great for protecting edges of roller doors from truck damage
- 3 standard sizes available however other sizes can be made to order to your particular specifications



Code	Description	Dimensions	Price Each	
			1-9	10+
AB8701	Fixed Yellow 'U' Bar High Bollard	1068x1220x115mm (HxWxD)	\$225.00	\$POA
AB8702	Fixed Yellow 'U' Bar Low Bollard	230x1220x115mm (HxLxD)	\$149.00	\$POA
AB8703	Fixed Yellow Standard Bollard	915x115mm (HxD)	\$98.00	\$POA

Safety Guard Rail Fencing

- Protect expensive equipment from forklift damage using bolt together post and panel modular system
- Heavy duty powder coat yellow steel construction
- Easily assembled and disassembled rail system
- Supplied with all necessary bolts and fixings
- We can supply and install this fencing system at your workplace - Contact us for a quotation
- Galvanised finish available on request



Workplace & Office Equipment

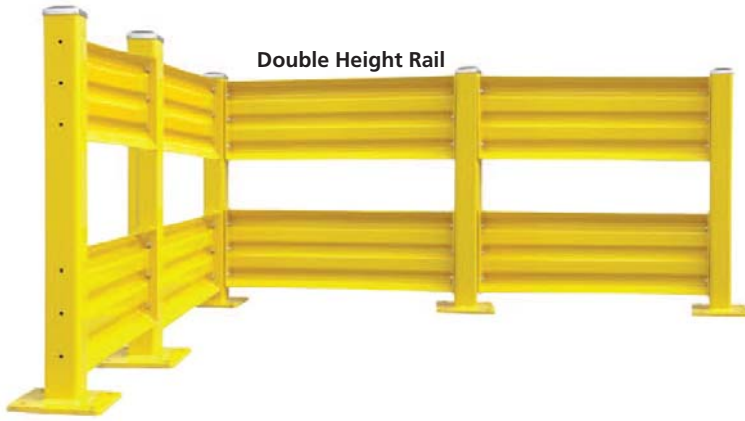

Double Height Rail

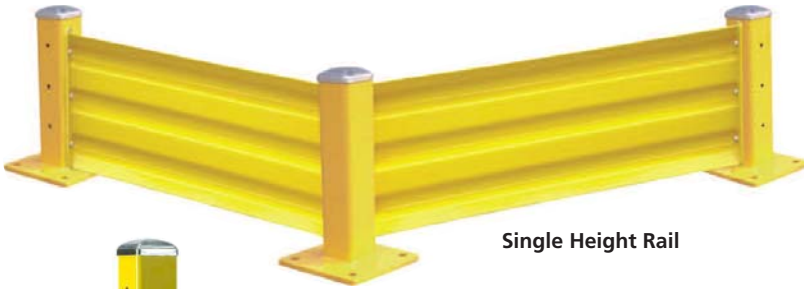

Single Height Rail



Double Height Post

Corner Post
Comes with bolt holes on two adjoining sides

Centre Post
Comes with bold holes on two opposite sides

Post Base Size
254x254x16mm



Single Height Post



Safety Rail

Price Each

Code	Description	Height	Length	1-9	10+
SG401	Single Height Corner Post (100x100mm)	470mm	-	\$90.00	\$POA
SG402	Single Height Centre Post (100x100mm)	470mm	-	\$90.00	\$POA
SG403	Double Height Corner Post (100x100mm)	1085mm	-	\$130.00	\$POA
SG404	Double Height Centre Post (100x100mm)	1085mm	-	\$198.00	\$POA
SG405	Safety Rail Section	370mm	1120mm	\$130.00	\$POA
SG406	Safety Rail Section	370mm	1730mm	\$160.00	\$POA
SG407	Safety Rail Section	370mm	2340mm	\$190.00	\$POA
SG408	Safety Rail Section	370mm	2945mm	\$258.00	\$POA

Verge Pedestrian Safety Barriers



Verge is a unique barrier solution providing a safe segregation of vehicles and people. Verge Barriers create a strong physical boundary between pedestrians and moving equipment such as forklifts, tow tugs and other vehicles used inside industrial warehouses and facilities.

Verge Safety Barriers with Handrail are fitted with a modular handrail attachment providing a complaint 1m high handrail to the walkway side of the Verge pedestrian barrier. The purpose of V-Rail is to create an ultimately safe passage offering support and assistance as well as a grab point in the event of a trip incident.

Features

- WHS Acceptance
- 2 heights and optional length kits
- Product is Galvanised, prior to powder coating
- Superior Strength and finish
- Fully modular
- Optional lengths to suit all requirements
- Accessory options. Eg. Gate and rails
- Flat pack
- Ease of installation
- 5 years warranty



Price Each

Code	Description	Price Each	
		1-5	6+
SBV001	Verge Barrier Kit 700mm high x 1000mm long	\$494.00	\$POA
SBV002	Verge Barrier Kit 700mm high x 2000mm long	\$596.00	\$POA
SBV003	Verge Barrier Kit 700mm high x 3000mm long	\$703.00	\$POA
SBV004	Verge Barrier Kit 700mm high x 4000mm long	\$807.00	\$POA
SBV005	Verge Barrier Kit 700mm high x 5000mm long	\$1133.00	\$POA
SBV010	Verge Barrier Kit 1000mm high x 1000mm long	\$532.50	\$POA
SBV012	Verge Barrier Kit 1000mm high x 2000mm long	\$635.40	\$POA
SBV013	Verge Barrier Kit 1000mm high x 3000mm long	\$741.50	\$POA
SBV014	Verge Barrier Kit 1000mm high x 4000mm long	\$845.00	\$POA
SBV015	Verge Barrier Kit 1000mm high x 5000mm long	\$1192.00	\$POA



Verge Self-Closing Swing Gates

The Verge Self-Closing Swing Gate Attachment gives you a continuous secure barrier whilst providing access points where required.

These gates can be placed in areas of general access or positioned for access of plant and equipment for maintenance or replacement purposes.



Price Each

Code	Description	Price Each	
		1-5	6+
SBVG1	Verge Self Closing Swing Gate (to suit 1000mm high barrier)	\$817.00	\$POA

Verge Pedestrian Safety Barriers



Verge Safety Barriers with Handrail are fitted with a modular handrail attachment providing a compliant 1m high handrail to the walkway side of the Verge pedestrian barrier. The purpose of V-Rail is to create an ultimately safe passage offering support and assistance as well as a grab point in the event of a trip incident. V-rail is essential for escape routes, to protect and guide when visibility is an issue in the event of power failure, fire and emergency evacuation.

Verge is unique as it provides two key safety features in one product. Not only does it offer substantial protection against vehicle traffic but, with the adaptability of the modular handrail, the Verge barrier provides a safe passage way for emergency evacuation, bringing compliance into the workplace.

Features

- WHS Acceptance
- Compliant 1m high handrail
- Provides a safe passageway for emergency exits
- Provides a grab point in event of trip/fall
- Offset by 100mm preventing tripping on the barrier
- Product is Galvanised, prior to powder coating
- Superior Strength and finish
- Fully modular
- Optional lengths to suit all requirements
- Accessory options. Eg. Gate and rails
- Flat pack
- Ease of installation
- 5 years warranty



Code	Description	Price Each	
		1-5	6+
SBVR01	Verge Barrier Kit 1000mm high x 1000mm long (with rail)	\$612.00	\$POA
SBVR02	Verge Barrier Kit 1000mm high x 2000mm long (with rail)	\$731.00	\$POA
SBVR03	Verge Barrier Kit 1000mm high x 3000mm long (with rail)	\$854.00	\$POA
SBVR04	Verge Barrier Kit 1000mm high x 4000mm long (with rail)	\$975.00	\$POA
SBVR05	Verge Barrier Kit 1000mm high x 5000mm long (with rail)	\$1303.00	\$POA
SBVEB	Elbow Joining Kit (for corners)	\$14.95	\$POA

Verge V-Stop Floor Angle

The fixed heavy-duty Floor Angle is designed to prevent pallets and forklift tines from protruding into the designated walkways



Code	Description	Price Each	
		1-5	6+
VR001	V-Stop Floor Angle 2000mm long (with fixings)	\$206.00	\$POA
VR002	V-Stop Floor Angle 2500mm long (with fixings)	\$236.00	\$POA
VR003	V-Stop Floor Angle 3000mm long (with fixings)	\$266.00	\$POA
VR004	Internal Corner 100x75x8mm	\$61.00	\$POA
VR005	External Corner 100x75x8mm	\$82.50	\$POA

Ball Fence Hand Rail System

- Modular handrail system that includes stanchions in a range of configurations
- Components are all hot dip galvanised
- Complies to AS 1657:2013
- Suitable for indoor and outdoor use
- Self closing gates available

Material: Post 48.3mm O.D. (40mm N.B.)
Handrail 42.4mm O.D. (32 N.B.)
Kneerail 33.7mm O.D. (25 N.B.)

Finish: Hot dip galvanised

Height: 1017mm ground to handrail centre
560mm ground to kneerail centre

Spacing: Max post spacing 2 metres centre to centre



Price Each

Code	Description	1-5	6+
BF001	Hand rail 32 N.B. x 6 metres	\$112.50	\$POA
BF002	Knee rail 25 N.B. x 6 metres	\$84.25	\$POA
BF003	End post (surface mount)	\$64.00	\$POA
BF004	End post (below ground)	\$64.00	\$POA
BF005	Through post (surface mount)	\$64.00	\$POA
BF006	Through post (below ground)	\$64.00	\$POA
BF007	Corner post (surface mount)	\$64.00	\$POA
BF008	Corner post (below ground)	\$64.00	\$POA
BF009	Ball-Fence gate (complete with 1.5 metre hoop) – Galvanised	\$564.00	\$POA
BF010	Ball-Fence gate (complete with 1.5 metre hoop) – Powder coated	\$648.00	\$POA
BF011	Ball-Fence gate post – Galvanised	\$114.00	\$POA
BF012	90mm surface mount bollard – Galvanised	\$181.00	\$POA
BF013	Bend 90° x 32 N.B.	\$27.50	\$POA
BF014	Bend 90° x 25 N.B.	\$20.80	\$POA
BF015	Closure bend	\$40.00	\$POA
BF016	Additional 1.5 metre gate hoop	\$128.00	\$POA
BF017	Slip joint 32 N.B.	\$4.80	\$POA
BF018	Slip joint 25 N.B.	\$3.20	\$POA
BF019	Through post adjustable foot	\$51.50	\$POA
BF020	Corner post adjustable foot	\$51.50	\$POA
BF021	Taper pin	\$6.40	\$POA
BF022	Ball-Fence toe board 100 x 6 x 6 metres – Galvanised	\$217.60	\$POA
BF023	Toe board saddle clamp – Galvanised	\$11.20	\$POA
BF024	Toe board corner clamp – Galvanised	\$16.00	\$POA

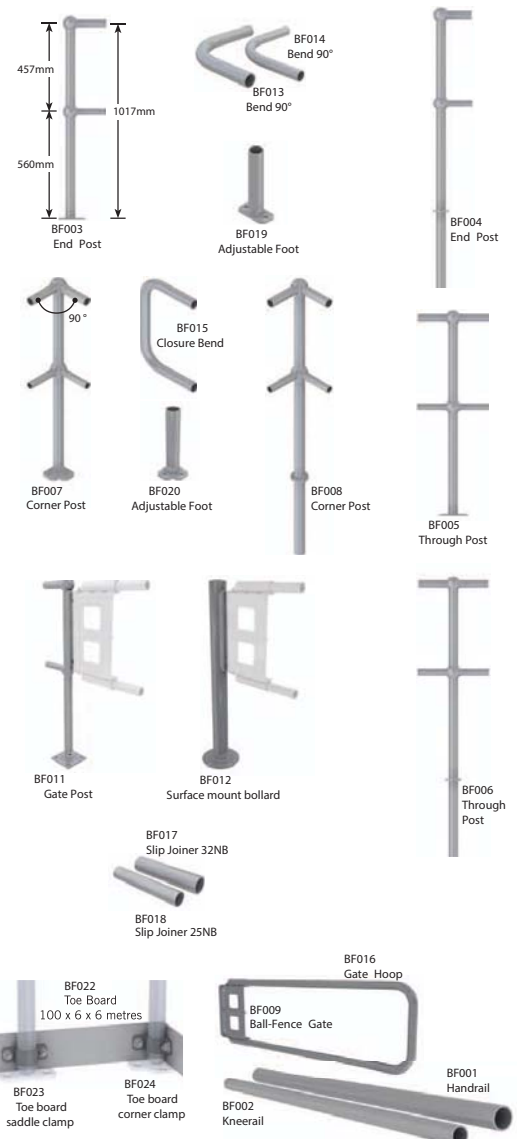

Ball Fence Gate

- Self-closing operation
- Compatible with Ball-Fence hand rail system
- Supplied with 42.4mm diameter galvanised hoop
- Can swing inward or outward
- Can be used in pairs for wider openings
- Gate Swing: 90 degrees
- Gate stop: Built-in
- Opening: Single gate 1.5 metres
- Max. open: Double gates 3 metres
- Min. open: No minimum
- Adjustment: Cut down on site
- Height: Top rail 1017mm above floor
- Clearance: Overhead clearance not applicable
- Mounting: Existing posts, walls, optional posts available
- Weight: 18kgs gate assembly with 1.5 metre hoop



Price Each

Code	Description	1-5	6+
BF009	Ball-Fence gate with hoop – Galvanised	\$564.00	\$POA
BF010	Ball-Fence gate with hoop – Galvanised & powder coated	\$648.00	\$POA
BF025	Gate to post fi xing kit – Up to 63mm diameter posts	\$6.00	\$POA
BF026	Gate to post fi xing kit – Up to 90mm diameter posts	\$6.00	\$POA
BF027	90mm surface mount bollard for mounting Ball-Fence	\$200.00	\$POA
BF011	Ball-Fence gate post – 48 x 1017mm	\$114.00	\$POA
BF016	Additional 1.5 metre gate hoop	\$128.00	\$POA

U Bars - Double Rail

- Three sizes available in below ground or surface mount models
- Heavy 3mm wall, 48.3mm diameter pipe
- Fully welded one-piece construction
- All models are galvanised and powder coated or galvanised only
- Supplied ready for installation with no assembly required



Price Each

Code	Description	1-5	6+
UB001	U-Bar double rail 1 metre surface mount – Gal. & powder coat	\$292.25	\$POA
UB002	U-Bar double rail 1 metre surface mount – Galvanised	\$210.00	\$POA
UB003	U-Bar double rail 1 metre below ground – Gal. & powder coat	\$316.75	\$POA
UB004	U-Bar double rail 1 metre below ground – Galvanised	\$206.50	\$POA
UB005	U-Bar double rail 1.5 metre surface mount – Gal. & powder coat	\$372.75	\$POA
UB006	U-Bar double rail 1.5 metre surface mount – Galvanised	\$261.00	\$POA
UB007	U-Bar double rail 1.5 metre below ground – Gal. & powder coat	\$416.50	\$POA
UB008	U-Bar double rail 1.5 metre below ground – Galvanised	\$269.50	\$POA
UB009	U-Bar double rail 2 metre surface mount – Gal. & powder coat	\$432.25	\$POA
UB010	U-Bar double rail 2 metre surface mount – Galvanised	\$281.75	\$POA
UB011	U-Bar double rail 2 metre below ground – Gal. & powder coat	\$474.25	\$POA
UB012	U-Bar double rail 2 metre below ground – Galvanised	\$294.00	\$POA

Two Piece Knock Down Bollard

- Soft, lightweight bollard takes the knocks without causing damage to vehicles
- Strong elastic joint ensures bollard returns to upright position
- Bollard can be removed from base



Price Each

Code	Description	Dimensions (Diameter x Height)	1-9	10+
B7435	Plastic 2 Piece Knock Down Flexible Bollard	100x1000mm	\$84.00	\$POA
B7436	Replacement Base Only	-	\$36.75	\$POA
B7437	Replacement Top Only	-	\$63.00	\$POA

One Piece Flexi Knock Down Bollard



- Durable one piece moulding
- Virtually indestructible (will not break or split)
- Rebounds after impact
- Built in reflective bands
- Available in two handy sizes

Price Each

Code	Description	Dimensions (Diameter x Height)	1-9	10+
B7438	Plastic 1 Piece Knock Down Flexible Bollard	80x450mm	\$35.00	\$POA
B7439	Plastic 1 Piece Knock Down Flexible Bollard	80x750mm	\$52.50	\$POA

T-Top Bollards

- Fluoro red post with reflective tape
- Heavy weight Rubber base
- Size: 1150mm High
- Complies to AS1742
- Separate tops available for replacement for damages from being run over by vehicles
- Rubber Base Weight: 6kg



Price Each

Code	Description	1-19	20-49	50+
B7310	T-Top Bollard (Base & Top)	\$39.50	\$33.50	\$POA
B7311	T-Top Bollard Top Only (used as replacements for damages)	\$28.00	\$25.20	\$POA

Traffic Cones

- Flexible fluoro PVC Traffic Cones
- Made to Australian Standards
- Colour: Orange
- Available in two sizes



Price Each

Code	Description	Dimensions	1-9	10-19	20+
TC450R	Traffic Cone Class 1 Reflective	450mm high	\$19.25	\$17.30	\$POA
TC750R	Traffic Cone Class 1 Reflective	700mm high	\$33.25	\$29.95	\$POA

Retractable Barrier Bar



- Extendable Bar – fits over traffic cones
- Size: extends up to 2m

Price Each

Code	Description	1-9	10-19	20+
B7579	Retractable Barrier Bar	\$32.50	\$29.00	\$POA

Rubber Wheel Chocks

- Helps prevent vehicles and machinery from rolling while parked or in delivery stage
- Manufactured from 100% recycled rubber
- Superior construction ensures the wheel chocks will not warp, crack, chip or rot
- UV stabilised
- Withstands all temperature extremes
- Helps prevent vehicles and machinery from rolling while parked or in delivery stage
- Size: 290x160x190mm (length x width x height)



Price Each

Code	Description	1-9	10-19	20+
RW290	Rubber Wheel Chocks	\$33.00	\$27.90	\$POA



Pallet Racking Column Guards

Pallet Racking Column Guards are a highly effective solution for preventing damage to racking and inventory by forklifts.

No matter how good your forklift drivers are, there will always be sometime when an accident or mistake happens when they crash into the pallet racking. You can avoid major injuries and pallet rack damage by installing these protection guards.

Damage and failure not only causes serious safety issues but disassembling, repair, reassembling and reloading of pallet racks add significantly to running costs.

- Conforms to AS4084:2012
- Size: 400mm high x 220mm deep



Price Each

Code	Description	1-9	10-19	20+
11327	Pallet Racking Column Guard	\$44.80	\$39.95	\$POA

Pallet Racking End Protectors



Pallet Racking End Protectors are a highly effective solution for preventing damage to racking and inventory by forklifts.

No matter how good your forklift drivers are, there will always be sometime when an accident or mistake happens when they crash into the pallet racking. You can avoid major injuries and pallet rack damage by installing these protection guards.

Damage and failure not only cause serious safety issues but disassembling, repair, reassembling and reloading of pallet racks add significantly to running costs.

- Single Bay End Protector to suit 838mm frame
- Double Bay End Protector to suit 838mm frame + 430mm space + 838mm frame
- Conforms to AS4084:2012



Single End Protector



Double End Protector

Price Each

Code	Description	Height	Overall Length	1-9	10+
11240	Stormax End Protectors (to suit single bay of racking)	400mm	1080mm	\$188.00	\$POA
11241	Stormax End Protectors (to suit double bay of racking)	400mm	2350mm	\$260.00	\$POA
11340	Schaefer 1 Piece End Protector (to suit single bay of racking)	400mm	1200mm	\$295.00	\$POA
11341	Schaefer 1 Piece End End Protectors (to suit double bay of racking)	400mm	2450mm	\$489.00	\$POA

Indoor Convex Mirrors

- Unbreakable polycarbonate face
- Suitable for Indoor use
- Suitable for pedestrian traffic applications
- Comes complete with wall mount and post mount brackets

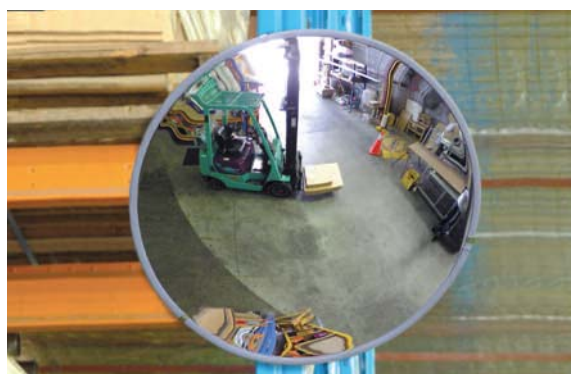

Price Each

Code	Description	Size	1-4	5-9	10+
M7601	Indoor Convex Mirror	300mm	\$106.00	\$95.40	\$POA
M7602	Indoor Convex Mirror	450mm	\$128.00	\$115.20	\$POA
M7603	Indoor Convex Mirror	600mm	\$160.00	\$144.00	\$POA
M7604	Indoor Convex Mirror	800mm	\$320.00	\$288.00	\$POA



Indoor Dome Convex Mirrors

- Economical convex mirror
- Lightweight
- For general surveillance of a broad area
- Three options available 90 degree, 180 degree, 360 degree view range

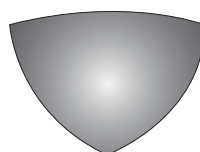

Corner Dome



Half Dome

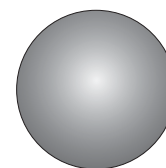

Full Dome

Price Each

Code	Description	Size	1-4	5-9	10+
M7611	Indoor Full Dome Convex Mirror	600mm	\$264.00	\$237.60	\$POA
M7613	Indoor Half Dome Convex Mirror	600mm	\$166.00	\$149.40	\$POA
M7616	Indoor Corner Dome Convex Mirror	600mm	\$84.00	\$75.60	\$POA

Outdoor Convex Mirrors

- Weather proof
- Unbreakable polycarbonate face
- High visibility orange visor
- Suitable for pedestrian traffic applications
- Comes complete with wall mount and post mount brackets



Price Each

Code	Description	Size	1-4	5-9	10+
M7629	Outdoor Convex Mirror	450mm	\$156.00	\$140.40	\$POA
M7630	Outdoor Convex Mirror	600mm	\$188.00	\$169.20	\$POA
M7631	Outdoor Convex Mirror	800mm	\$320.00	\$288.00	\$POA
M7632	Outdoor Convex Mirror	1000mm	\$395.00	\$355.50	\$POA

Modular Rubber Speed Humps

- 2 size body length and rounded end sections
- Moulded from high quality natural rubber in either black or yellow
- When laid in an alternating pattern they meet the Australian Standard for colour, height, shape and ramp angle
- Suitable for car parks, schools, shopping centres and factory complexes
- Built in bridge design for cables or hoses
- Quiet and smooth in operation
- Fixings supplied



Code	Description	Dimensions	Price Each		
			1-9	10-19	20+
AB1570	Yellow Module	250x350x50mm	\$30.00	\$25.50	\$POA
AB1571	Black Module	250x350x50mm	\$30.00	\$25.50	\$POA
AB1572	Black/Yellow 1 Metre Long Module	1000x350x50mm	\$112.50	\$95.60	\$POA
AB1573	Yellow End Cap (each)	250x350x50mm	\$22.00	\$19.50	\$POA
AB1574	Black End Cap (each)	250x350x50mm	\$22.00	\$19.50	\$POA



Modular Steel Speed Humps

Ideal for car parks, shopping centres or factory complexes

- Designed to comply with AS/NZS 2890.1:2004
- More than four times the load bearing contact area with the road surface than competitor's products
- Can be used with or without end caps
- Comes complete with all fixings
- Truly independent modules for easy removal
- Does not need a rubber underlay to prevent rattle
- Concealed fixings remain accessible
- Modules have a built in bridge design to accommodate hoses or cables

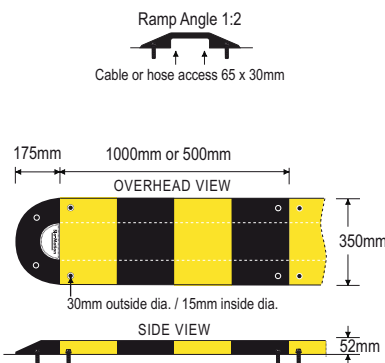

Specifications

- Top Skin: 3mm floor plate
- Length: 1 metre or 1/2 metre
- Width: 350mm (in the driving direction)
- Height: 52mm
- Ramp angle: 2:1
- Weight: AB1581 – 16.5kgs
AB1580 – 9.2kgs
AB1582 – 5.2kgs/pair (rubber)
AB1583 – 5kgs/pair (steel)
- Fixings: Supplied

Code	Description	Size	Price Each		
			1-9	10-19	20+
AB1580	Steel Speed Hump - 0.5 metres	350x500mm (WxL)	\$231.25	\$208.10	\$POA
AB1581	Steel Speed Hump - 1 metre	350x1000mm (WxL)	\$297.85	\$268.00	\$POA
AB1582	Rubber End Caps to suit (1 pair)	175x350mm	\$55.50	\$49.95	\$POA
AB1583	Steel End Caps to suit (1 pair)	175x350mm	\$233.10	\$209.80	\$POA
AB1584	Optional Gravel Spikes (used for fixing into loose surfaces)	300x12mm	\$9.25	\$8.30	\$POA

One Way Road Spike Access Humps

- Extremely strong construction, 6mm top plate
- Hi-Vis Lime Green with Hi-Vis Orange spikes
- Deters access from unauthorised direction
- All teeth operate independently of each other
- Low profile design ensures legal vehicle clearance
- Soft approach due to low ramp angle
- Comes complete with all fixings
- Available in 1000 and 500mm lengths



Specifications

Finish: Lime green & Hi-Vis orange powder coat
 Length: 500 or 1000mm
 Width: 380mm
 Height: Teeth up 95mm Teeth retracted 50mm
 Weight: 1 metre = 26kg (approx)

Please Note

Always check with your local authority or controlling body to ensure one way access spikes are allowable in your situation (this is the end users responsibility). These one way access spikes MUST always be installed with an awareness sign kit (code AB1593). One way access spikes should always be placed clear of intersections and curved roadways. Failure to heed these warnings will void all warranties.

Code	Description	Size	Price Each	
			1-5	6+
AB1590	Road Spike Access Hump Module - 0.5 metres	380x500mm (WxL)	\$683.40	\$POA
AB1591	Road Spike Access Hump Module - 1 metre	380x1000mm (WxL)	\$1057.50	\$POA
AB1592	End Caps to suit (pair)	380mm wide	\$298.00	\$POA
AB1593	*Road Spike Warning Sign Kit	*(as below)	\$365.50	\$POA

*Kit includes 1 x galvanised sign post 2.8m long, 1 warning sign & 1 no-entry sign as pictured

Cable & Hose Protectors

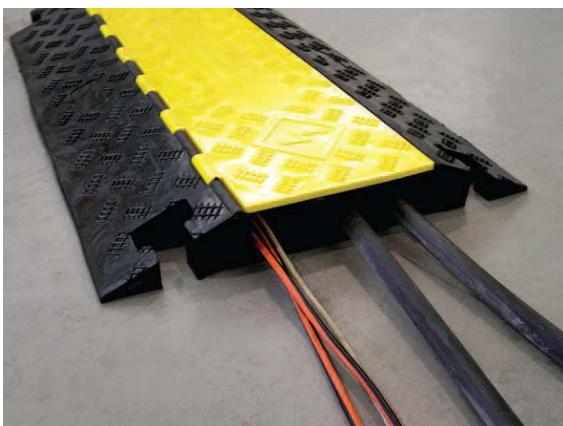

- Provide safe passage for pedestrians
- Large channels to suit a variety of cable and hose sizes
- Suitable for indoor or outdoor use
- Checker plate pattern for increased traction
- Easy to interlock
- Highly visible yellow lid
- Non-conductive construction
- Hinged lid for easy access to cables
- Fixing Holes for more permanent application
- Recessed hand grip

Specifications

Length: 900mm
 Height: 75mm
 Width: 500mm
 Weight: 20kg
 No. of Channels: 3
 Channel Height: 30mm
 Channel Width: 65mm

Code	Description	Price Each		
		1-9	10-19	20+
AB7850	Cable & Hose Protector	\$179.00	\$152.10	\$POA

Carpark Rubber Wheel Stops

- Designed to catch front wheels of vehicle while still allowing pedestrian access between parking bays
- Also suitable in factories and warehouses to prevent trolley and forklifts bumping walls etc
- Complies AS/NZS 2980.1:2004
- Resistant to UV, moisture, oil and extreme Temperatures
- Length: 1650mm
- Height: 100mm
- Width: 160mm (at base)
- Weight: 19 kg
- 3 fixing points



Code	Description	Price Each		
		1-9	10-19	20+
B7845	Carpark Rubber Wheel Stops	\$74.80	\$67.30	\$POA
B7846	Gravel Spike (used for loose ground surfaces) 12x300mm	\$6.50	\$5.20	\$POA



CUSTOM PRINTING AVAILABLE
 Contact us for a quotation
1800 750 900



Rubber Corner Protectors

- Ideal for tight parking areas
- Made in rubber with bright visible stripes
- Comes in 790mm lengths
- Fixing is with 6 anchor bolts or adhesive fix

Code	Description	Price Each		
		1-9	10-19	20+
AB7848	Rubber Corner Protectors	\$28.60	\$25.75	\$POA

Custom Logo Matting

- A great way to get your message across to everyone that comes through your door
- Hard wearing nylon plush pile makes for a clean cut image with a long life
- Rubber backing and borders
- Machine washable

Standard Sizes Available (Width x Length)

- 600x900mm
- 900x1200mm
- 900x1500mm
- 900mm runner

Contact us for pricing on your requirements

 **1800 750 900**



Tube Tred Matting

- PVC tubular matting can be cut to any length or shape
- Soft surface drains and resists oils, chemicals and alkalis
- Ideal for wet areas like bars, boats, commercial kitchens and food preparation areas etc
- Available in standard size of 900x2000m and also in 12 metre long rolls which can be cut to make smaller mats

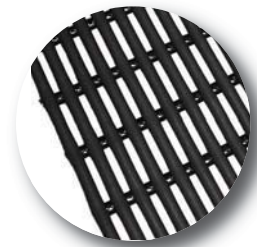
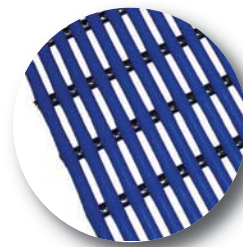

Price Each

Code	Description	Size (Width x Length)	Colour	1-3	4+
TM20BL	Tube Tred Mat	900x2000mm	Blue	\$266.70	\$POA
TM20BK	Tube Tred Mat	900x2000mm	Black	\$266.70	\$POA
TM12BL	Tube Tred Matting	900mm wide (12metre roll)	Blue	\$1144.50	\$POA
TM12BK	Tube Tred Matting	900mm wide (12metre roll)	Black	\$1144.50	\$POA

Ribbed Entrance Matting

- Effective and economical mat for medium traffic areas
- Attractive bi-level construction traps dirt
- Coarse fibres scrape dirt and debris from shoes
- Solution dyed to prevent fading
- Easy to clean and dries quickly
- Available in a range of colours as listed

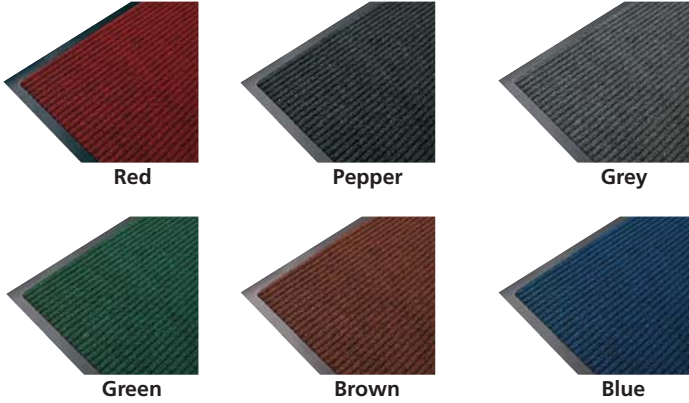

Price Each

Code	Description	Size (Width x Length)	Colour	Price Each	
				1-3	4+
RM600	Ribbed Entrance Mat	600x900mm	Please specify	\$48.40	\$POA
RM900	Ribbed Entrance Mat	900x1500mm	Please specify	\$114.50	\$POA
RM1200	Ribbed Entrance Mat	1200x1800mm	Please specify	\$184.90	\$POA

*Please specify your preferred colour when placing your order



Safety Message Matting

- Hard wearing nylon plush makes for easy clean cut images with long life
- PVC Backing and borders
- Great for entrance to warehouse and hazardous areas
- Size: 900 x 1500mm (width x length)



Price Each

Code	Description	Message	Size (Width x Length)	1-3	4+
SM901	Safety Message Mat	Safety Starts Here	900x1500mm	\$282.20	\$POA
SM902	Safety Message Mat	Stop Think Safety	900x1500mm	\$282.20	\$POA
SM903	Safety Message Mat	Watch Your Step	900x1500mm	\$282.20	\$POA

Anti-fatigue Safety Cushion Matting

- Popular general purpose safety mat
- Comfort non-slip mat
- Bevelled edges for safety
- Optional grease resistant formula
- Ideal for factories, kitchens, food preparation areas, boats and behind counters



General Purpose



Grease Resistant



Workplace & Office Equipment

Price Each

Code	Description	Type	Size (Width x Length)	1-3	4+
CM500	Anti-fatigue Safety Cushion Mat	General Purpose	600x900mm	\$47.70	\$POA
CM900	Anti-fatigue Safety Cushion Mat	General Purpose	900x1500mm	\$68.50	\$POA
CM500R	Anti-fatigue Safety Cushion Mat	Grease Resistant	600x900mm	\$58.50	\$POA
CM900R	Anti-fatigue Safety Cushion Mat	Grease Resistant	900x1500mm	\$107.70	\$POA



Anti-Fatigue Comfi Tred Matting

- Smooth surface for easy cleaning
- Unique base designed to relieve the strain of constant standing
- Suction cups under to prevent movement
- Bevelled edges for added safety
- 100% natural rubber



Price Each

Code	Description	Size (Width x Length)	1-3	4+
CT900	Anti-fatigue Comfi Tred Mat	600x900mm	\$79.00	\$POA
CT1200	Anti-fatigue Comfi Tred Mat	900x1200mm	\$129.00	\$POA

