



Sydney

Tel: (02) 8865 1800

Fax: (02) 8865 1830

Melbourne

Tel: (03) 9982 4570

Fax: (03) 9982 4575

Brisbane

Tel: (07) 3181 5630

Fax: (07) 3181 5635

mezzanine floors

double the space in the same place



don't
move out –
move up!

A **RAISED STORAGE PLATFORM** is the fast & economic way to add extra floor space within the shell of an existing building.

With increasing building costs and rental fees, every square metre of your office and warehouse area needs careful planning and design to give maximum space efficiency.

RAISED STORAGE PLATFORMS are free standing systems which do not depend on the structure of the existing building.

This unique system is completely demountable to make relocation easy. Structure of the platform will be carefully considered by our engineer for any desired weight loadings.



typical beam connections

side mounted cleats

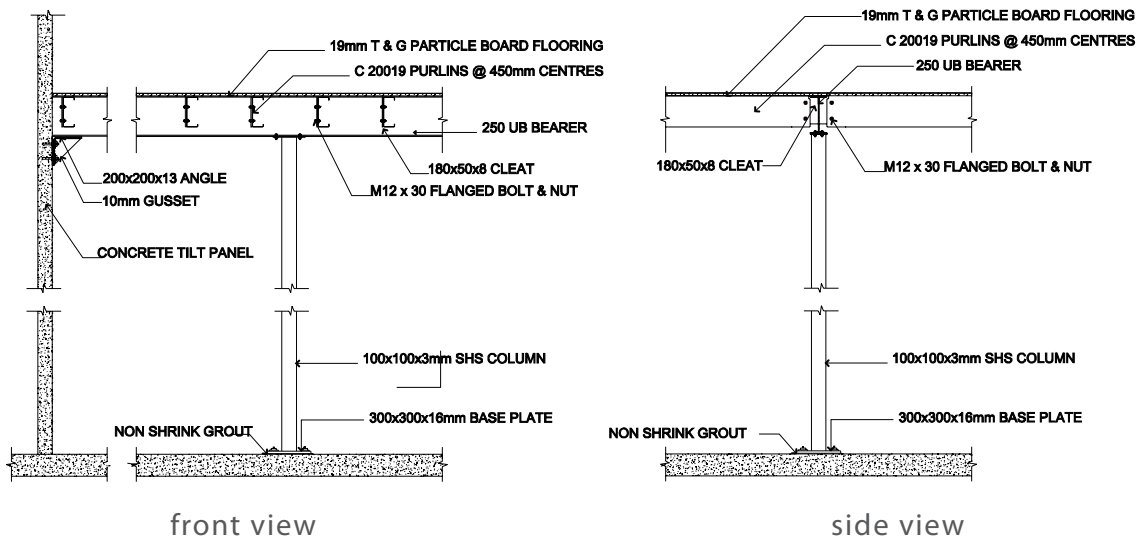

top mounted cleats

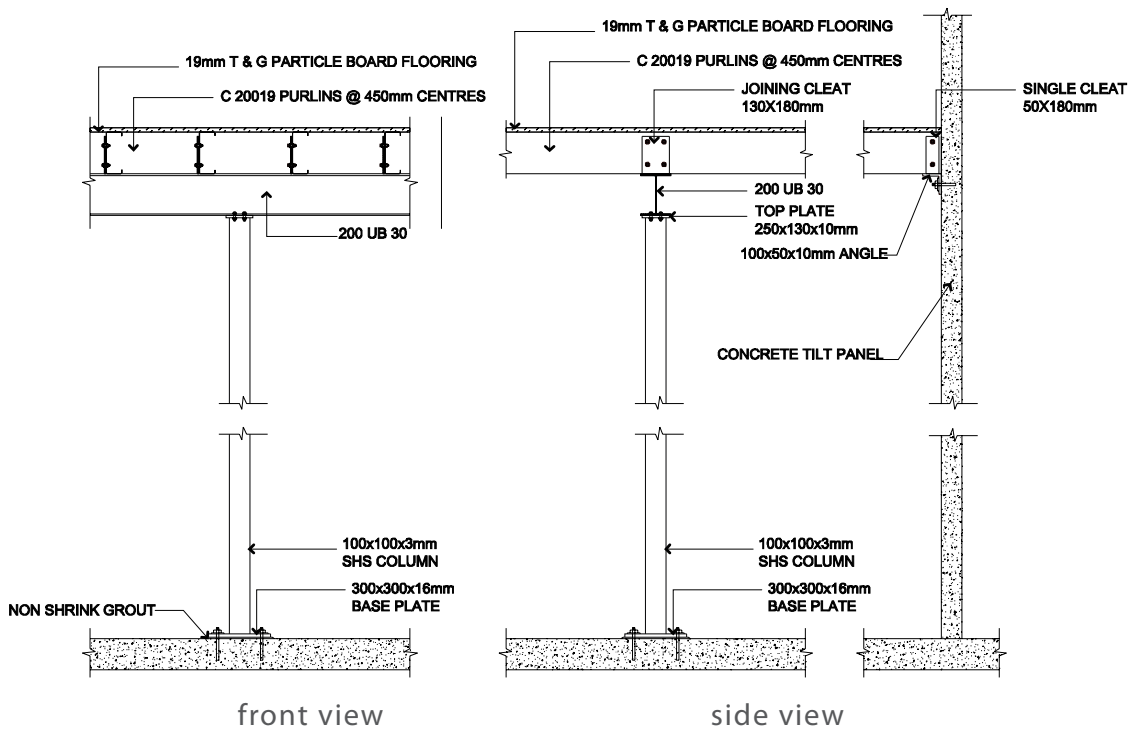

completely stand alone – easily relocated

elevated office areas



ELEVATED OFFICE AREAS – MEZZANINE FLOORS

are most efficient way of achieving much need office space without sacrificing your limited warehouse area

Ideal for

- Extra Offices
- Lunch Rooms
- Storage space
- Computer rooms
- Secure rooms
- Staff rooms
- Bathrooms

let us elevate your thinking



walkovers



STRUCTURAL PLANT PLATFORM



quality makes
the difference!

Ideal for servicing

- Air conditioning units
- Food Processing Equipment
- Holding Tanks
- Overhead Cranes
- Plant & machinery
- Printing Equipment
- Pump Stations

staircases | ladders | ramps

staircases

welded staircase which has chequor plate treads. Handrails are also fitted to either one or two sides of the staircase as per requirements. These items are all manufactured to meet Australian Standards AS 1657-1992

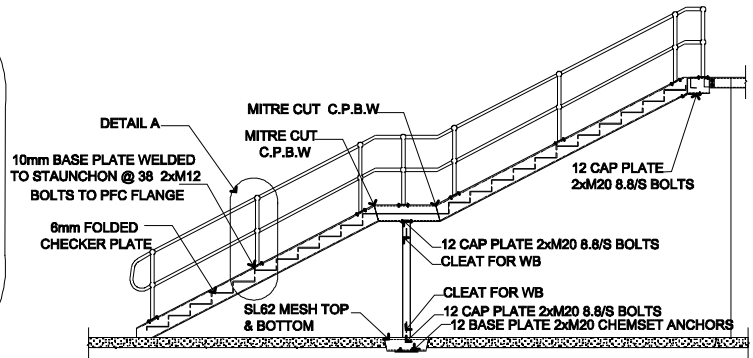
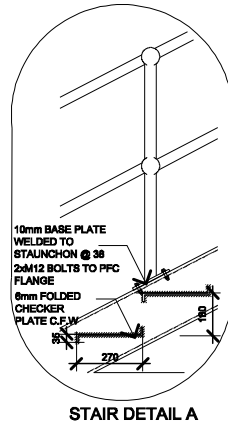

staircase detail



OPEN TREAD STAIRCASE



RAMP



STAIRLADDER
Ideal for tight areas

stairladders

Stairladders are another option to consider where floor area is scarce. A stairladder has an incline of between 60° - 70° allowing them to be placed in confined spaces. AS 1657-1992 5.6.1



CLOSED TREAD STAIRCASE

gates



CLOSED SLIDING ACCESS GATE



OPEN SLIDING ACCESS GATE

sliding access

are a simple but most efficient means of providing a loading point on your Raised Storage Platform

roll over safety

The roll over safety gate provides a safe loading area on the edge of a platform, for goods. The purpose of the roll over gate is to provide the highest level of safety at all times as goods are loaded and unloaded from platform



ROLL OVER SAFETY GATE



self closing swinging gate

The self closing swinging gate that

another option that is used in places where a sliding gate can't be used e.g. Confined spaces



DOUBLE SWING GATE



SELF CLOSE SWING GATE



handrails | kickplates

safety rails

Australian standards requirements, to which our system is fully compliant. The ball tube feature adds a finishing touch along with our folded kickrail. These items are galvanised as a standard finish, however, specific colours can be requested.

ball tube handrail sy



flooring



particle board

Ideal for applications such as light storage and office use.
Not recommend for pallet jacks



cfc-compressed fibre concrete

High fire resistant, recommended for wet areas and
high point loading e.g. Pallet jacks



grid mesh

Has an extra anti slip surface which is ideal for walkovers, catwalks, ramps,
roof top platforms and applications where lighting can be used from above.



plywood

A strong durable pre sanded
panel recommended for high
point loading e.g. Pallet jacks/
racking

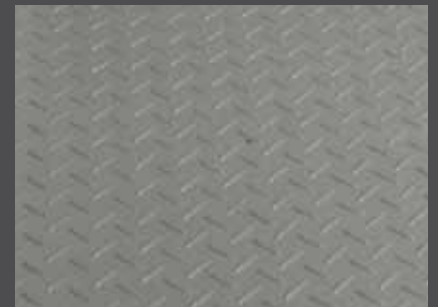

chequor plate

The pattern retains non
slip characteristics which is
recommended for walkways,
ramps and non slip areas



Sydney

Tel: (02) 8865 1800

Fax: (02) 8865 1830

Melbourne

Tel: (03) 9982 4570

Fax: (03) 9982 4575

Brisbane

Tel: (07) 3181 5630

Fax: (07) 3181 5635